

Lengthening Reconstruction Surgery for Congenital Femoral Deficiency

Dror Paley

Rubin Institute for Advanced Orthopedics, The International Center for Limb Lengthening, Sinai Hospital, Baltimore, Maryland, U.S.A.

Shawn C. Standard

Rubin Institute for Advanced Orthopedics, Sinai Hospital, Baltimore, Maryland, U.S.A.

INTRODUCTION

Congenital femoral deficiency (CFD) is a spectrum of severity of femoral deficiency and deformity. Deficiency implies a lack of integrity, stability, and mobility of the hip and knee joints. Deformity refers to bone malorientation, bone malrotation, and soft tissue contractures of the hip and knee. Both deficiencies and deformities are present at birth, nonprogressive, and of variable degree.

CLASSIFICATION

Existing classifications of congenitally short femora and proximal femoral focal deficiencies are descriptive but are not helpful in determining treatment. A recent longitudinal follow-up of different classification systems (1) showed that they were inaccurate in predicting the final femoral morphology based on initial radiographs. The Paley classification system (Fig. 1) is based on the factors that influence lengthening reconstruction of the congenitally short femur (2).

Paley Classification of Congenital Femoral Deficiency (Fig. 1)

Type 1: "intact femur" with mobile hip and knee

- a. Normal ossification proximal femur
- b. Delayed ossification proximal femur

Type 2: "mobile pseudarthrosis" with mobile knee

- a. Femoral head mobile in acetabulum
- b. Femoral head absent or stiff in acetabulum

Type 3: "diaphyseal deficiency" of femur

- a. Knee motion 45° or more
- b. Knee motion less than 45°
- c. Complete absence of femur

Type 4: "distal deficiency" of femur

Knee joint mobility/deficiency rather than hip joint mobility/deficiency is the most important determining factor for functional outcome and reconstructibility in cases of CFD. Paley Types 1 and 2 CFD are the most reconstructible. A wide spectrum of hip and knee dysplasia and deformity exists in Type 1 cases. Because Type 1 is the type most amenable to lengthening, it merits subclassification according to factors that require correction before lengthening can be performed.

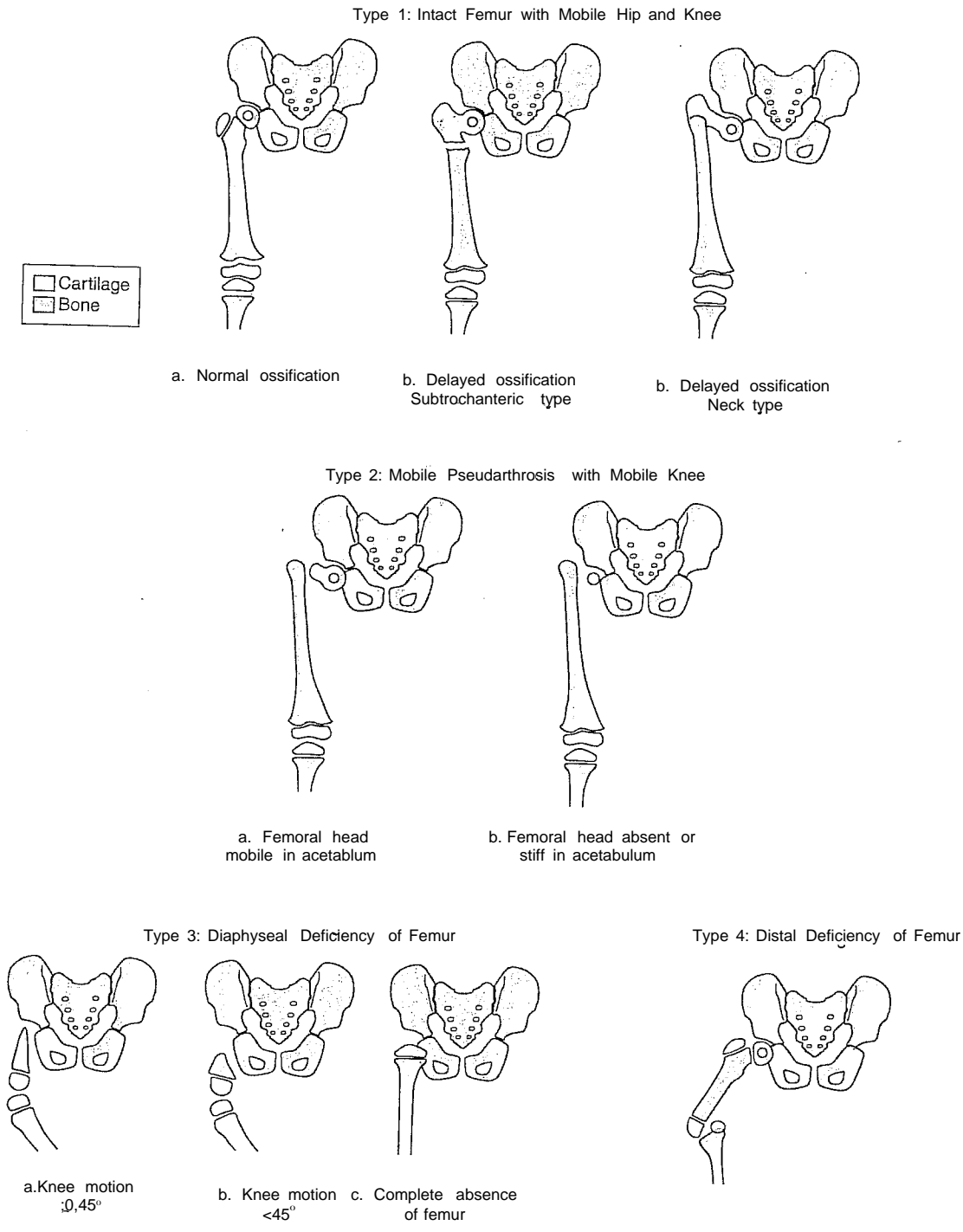

Figure 1 Paley classification of congenital femoral deficiency. Source: Figure copyrighted to the Rubin Institute for Advanced Orthopedics.

**TYPE 1 CONGENITAL FEMORAL DEFICIENCY: INTACT FEMUR
 Hip and Knee Considerations**

Type 1 CFD is the type that is most reconstructible. Before lengthening, significant bone deformities and soft tissue contractures of the hip and knee should be reconstructed. At the hip, if the acetabulum has a center edge (CE) angle of more than 20°, the neck shaft angle is more than 110°, and the greater trochanter is not significantly overgrown such that the medial proximal femoral angle (MPFA) is not less than 70°, no hip surgery is required before the first lengthening. At the knee, if the fixed flexion deformity (FFD) is less than 10°, the patella tracks with no subluxation laterally and no evidence of significant rotary subluxation or dislocation

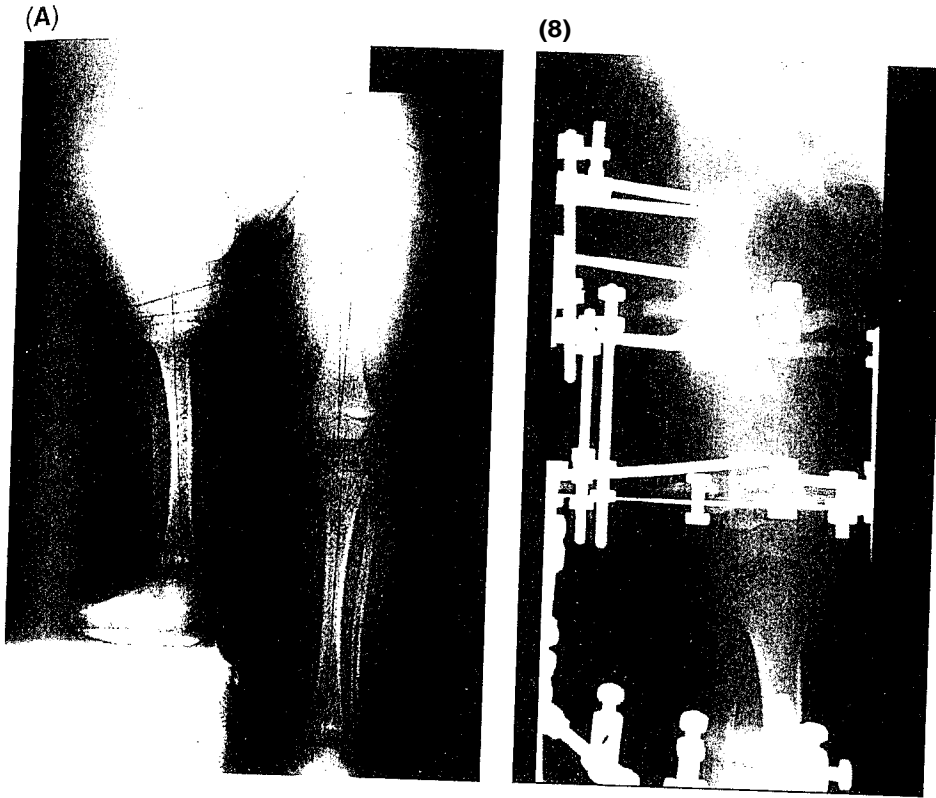

Figure 2 (A) Radiograph of patient with Paley Type 1a congenital femoral deficiency. The femora/neck is ossified and has significant coxa vara. (B) Radiograph shows initial lengthening with concurrent proximal subtrochanteric osteotomy for coxa vara correction. The lengthening is performed through the distal osteotomy site, and the external fixator bridges the knee joint to prevent subluxation and dislocation.

If the tibia on the femur is present, the knee does not require surgical reconstruction before lengthening (Fig. 2). If however, any of these criteria are not met, the hip and/or knee should be reconstructed before the first lengthening.

Acetabular Dysplasia

It is very common for even mild cases of CFD to include acetabular dysplasia, which predisposes the femoral head to subluxation during lengthening. A CE angle less than 20° before femoral lengthening is an indication for pelvic osteotomy. The acetabular dysplasia associated with CFD is not like that associated with developmental dysplasia of the hip. The deficiency is not predominantly anterolateral. The deficiency is more superolateral, often with a hypoplastic posterior lip of the acetabulum. Therefore, Dega osteotomy is the method we prefer over the Salter osteotomy or Millis-Hall modification of the Salter osteotomy (combining innominate bone lengthening with the Salter by using a trapezoidal instead of a triangular graft), because improved coverage can be gained with Dega osteotomy (3). Dega osteotomy is best performed when the patient is two years of age but can be performed in older patients if the triradiate cartilage remains open (Fig. 3).

Proximal Femoral Deformities

The proximal femoral deformity of CFD is not a simple coxa vara in most cases. It is a complex combination of bone deformities in the frontal, sagittal, and axial planes, combined with soft tissue contractures affecting all three planes. The severity of these deformities is often mild to moderate in Type 1a cases but is usually severe in Type 1b cases.

In more severe cases, the obvious coxa vara is associated with an abduction contracture of the hip. If the coxa vara is corrected on its own, the abduction contracture will be uncovered. This contracture will prevent full valgus correction and/or will prevent the hip from returning to a neutral position relative to the pelvis. The abduction contracture causes a fixed pelvic tilt,

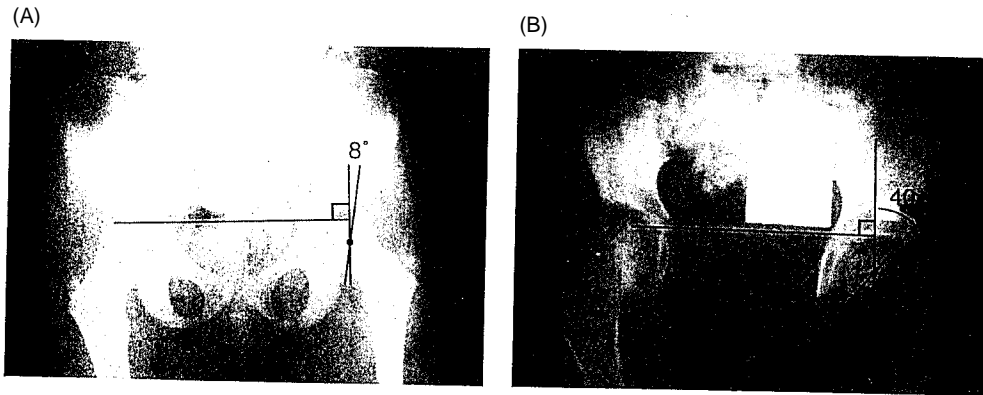

Figure 3 (A) Three-year-old female patient with Paley Type 1a congenital femoral deficiency and concurrent right hip dysplasia shown by the diagonal acetabular sourcil and a center edge angle of 8° (left center edge angle = 25°). (B) Postoperative radiograph after Dega osteotomy shows corrected dysplastic acetabulum.

which makes the limb length discrepancy (LLD) appear less than it was before surgery. In the presence of an open growth plate or a nonossified neck/subtrochanteric segment, the abduction contracture leads to recurrence of the coxa vara through these cartilaginous structures.

FFD of the hip usually accompanies severe coxa vara. The magnitude of the FFD often is masked by extension deformity in the bone of the proximal femur. External rotation deformity of the distal relative to the proximal femur (retroversion) is always present because of a combination of bony torsion and contracture of the piriformis muscle. The correction of these deformities is accomplished with a new surgical procedure, the *superhip procedure* (SUPER is an acronym for Systematic Utilitarian Procedure for Extremity Reconstruction).

SUPERHIP PROCEDURE (FIG. 4)

Step 1: Incision and Reflection of the Anterior Flap

A long, slightly concave anterior incision is made over the posterolateral border of the femur, from the iliac wing (starting 4 to 6 cm posterior to the anterior superior iliac spine) to one-third the way down the femur. A second, S-shaped incision is made from the lateral side of the patellar tendon, extending proximally in line with the intermuscular septum at the level of the knee joint, leaving a bridge of intact skin between the two incisions. The subcutaneous tissues are dissected off the fascia lata, reflecting the flap of skin and subcutaneous tissues anteriorly. The limit of the dissection of the proximal incision is the interval between the tensor fascia lata (TFL) and the sartorius. Distally, the fascia lata is exposed from the patella to the intermuscular septum. In very short femora, the two incisions are connected and the anterior flap is reflected as one (Fig. SA and B).

Step 2: Reflection of the Fascia Lata and Tensor Fascia Lata Muscle

The fascia is split longitudinally at the TFL-sartorius interval, with care taken to stay on the TFL side to avoid injury to the lateral femoral cutaneous nerve. The fascial incision is extended distally to the lateral border of the patella, ending at the tibia. The posterior split of the fascia lata starts distally and posterior at the intermuscular septum, and extends proximally up to the interval between the TFL and gluteus maximus. If knee ligamentous reconstruction is not required, the fascia lata is cut distally at the tibia and is reflected proximally. If ligamentous reconstruction with use of the fascia lata is planned, the fascia lata is cut proximally and reflected distally. To reflect the fascia lata, it has to be dissected free of all the overlying subcutaneous tissue, including that under the skin bridge between the two incisions. At the proximal end, the TFL muscle is reflected proximally and posteriorly on its posterior pedicle. Its anterior vascular pedicle (terminal branch of the lateral femoral circumflex vessels) can be cauterized and cut. Care should be taken to separate the tensor muscle from the underlying gluteus medius. The two muscles might be adherent to each other. The gluteus inserts on the greater trochanter, but the tensor passes over the trochanter (Fig. SC).

(A) Paley Type 1b: Subtrochanteric Delayed Ossification

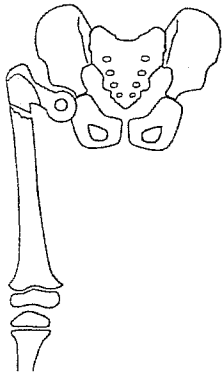

- Bone deformities:
- Varus
 - Extension
- Soft-tissue contractures:
- Abduction
 - Flexion
 - External rotation

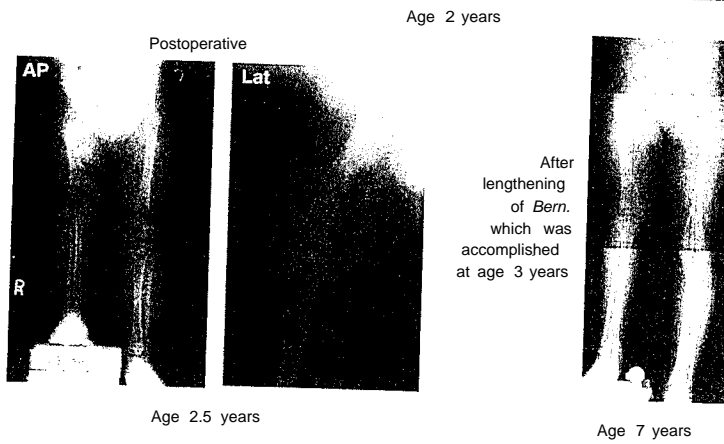
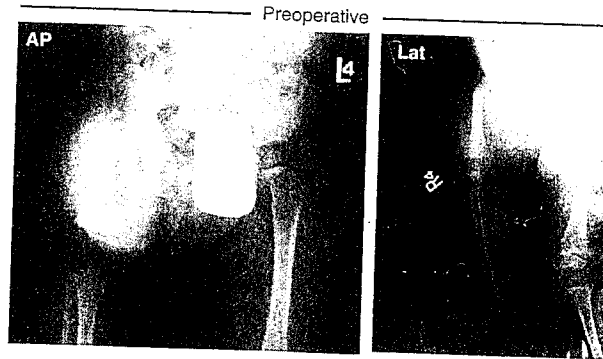

(B) Paley Type 1b: Femoral Neck Delayed Ossification

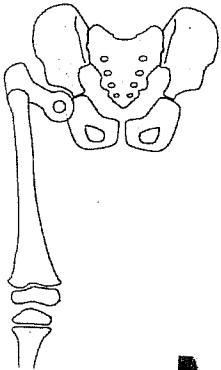

- Bone deformities:
- Varus
 - Extension
- Soft-tissue contractures:
- Abduction
 - Flexion
 - External rotation

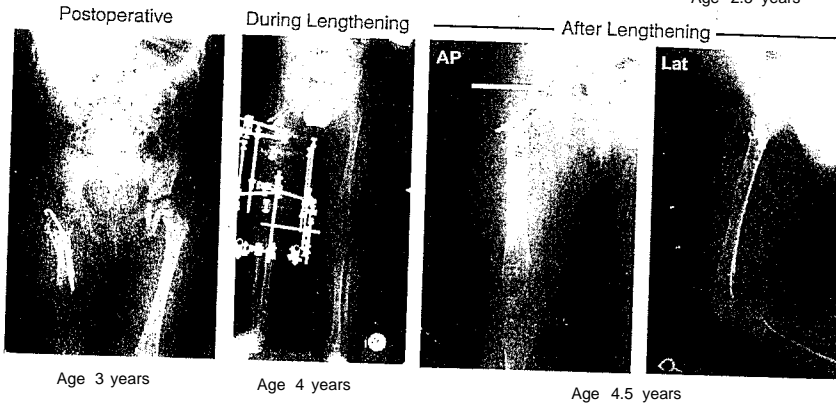
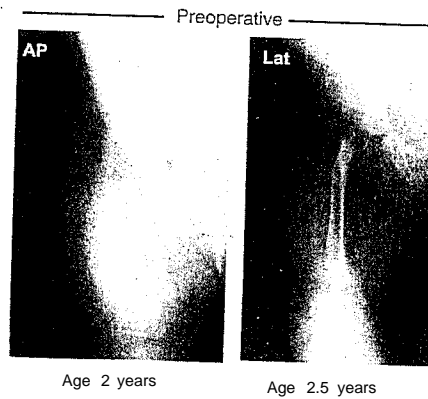

Figure 4 Radiographic examples of superhip procedure for Paley Type 1b congenital femoral deficiency. (A) Subtrochanteric delayed ossification. (B) Femoral neck delayed ossification. Abbreviations: AP, anteroposterior; Lat, lateral. Figure copyrighted to the Rubin Institute for Advanced Orthopedics.

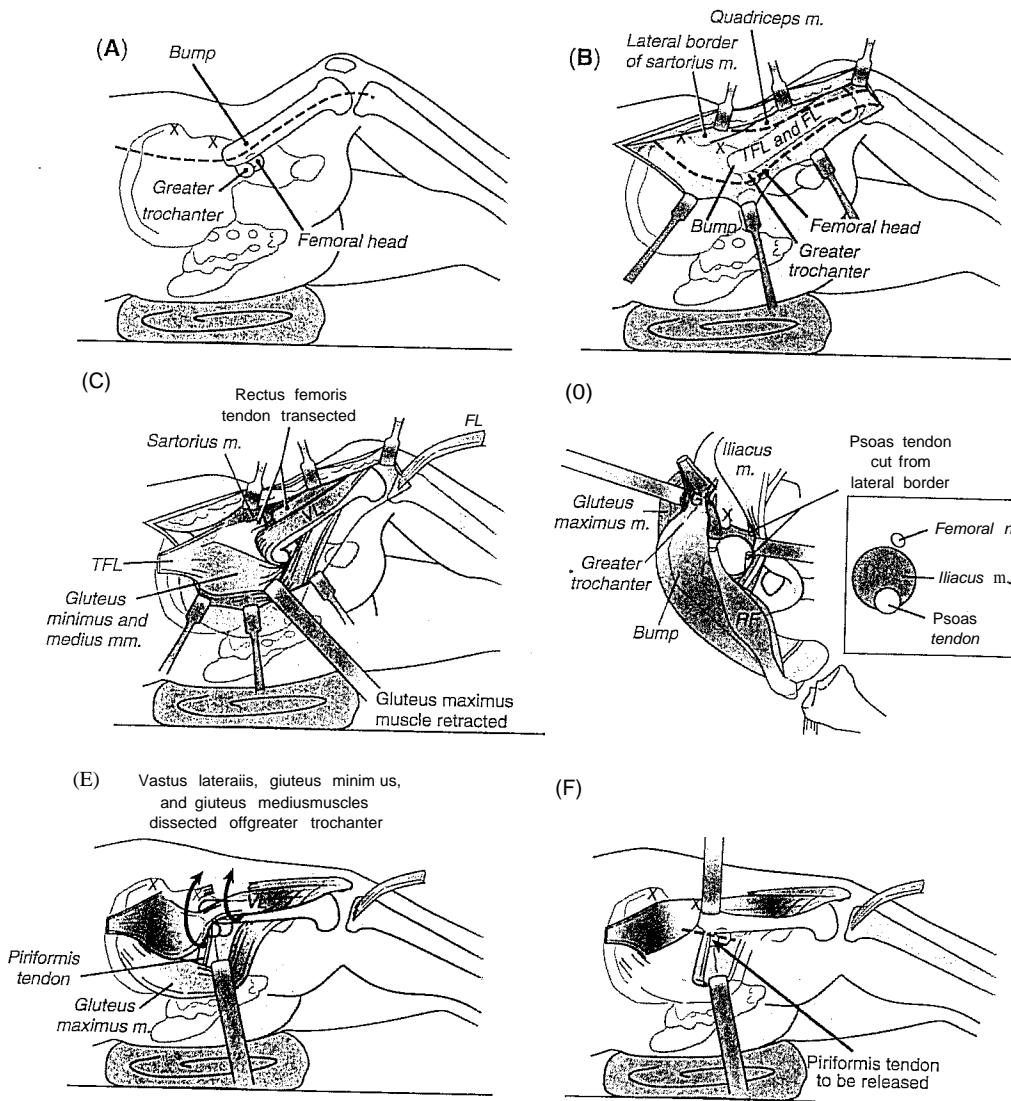

Figure 5 Superhip procedure. (A) Incision. (B) Reflection of anterior flap. A point 4 to 6 cm posterior to the anterior superior iliac spine is marked on the skin, and the lateral "bump" is marked on the skin. These two points are connected with a curvilinear line that extends distally on the posterior margin of the vastus lateralis muscle belly. The second incision is a distal "S" incision that begins at the level of the lateral intramuscular septum on the side of the thigh and proximally at the level of the superior pole of the patella and extends to the lateral margin of the patella tendon to the tibial tubercle. The anterior flap is dissected off the deep fascia to the midline of the thigh. (C) Reflection of fascia lata and tensor fascia lata (TFL) muscle. The anterior and posterior margins of the fascia lata are dissected as described, with the fascia lata being released proximally at the musculotendinous junction of the TFL muscle. The fascia lata is reflected distally to its insertion on Gerdy's tubercle of the proximal tibia. The TFL muscle is dissected off the gluteus minimus and medius and reflected proximally. (D) Hip flexion contracture release. After the TFL muscle is reflected proximally, the dissection is continued medially under the sartorius muscle. The rectus femoris tendon is the first structure identified as it inserts on the anterior inferior iliac spine. This tendon is released, and the psoas muscle and tendon are then identified. Before release of the psoas tendon, the femoral nerve, which is adjacent to the psoas tendon, is identified and decompressed. (E and F) Release of abduction and external rotation contracture. The confluent tendinous portions of the hip abductor muscles (gluteus minimus and medius muscles) and the vastus lateralis muscle are sharply dissected off the cartilaginous greater trochanter, creating a continuous musculotendinous sling. This release resolves the abduction contracture and allows access to the piriformis tendon. *Abbreviations:* m, muscle; FL, fascia lata; mm, muscles; VL, vastus lateralis; RF, rectus femoris. *Source:* Figure copyrighted to the Rubin Institute for Advanced Orthopedics.

Step 3: Hip Flexion Contracture Release

The dissection of the flexors is performed posterior to the sartorius to find the anterior inferior iliac spine. The rectus femoris tendon insertion is identified at the inferior spine. The direct and reflected head of the rectus femoris tendons are transected. Just medial to the rectus are the iliopsoas muscle and tendon. The psoas tendon is cut, leaving the intact iliacus muscle

fibers to bridge the gap. Care should be taken to avoid injury to the femoral nerve, which lies anterior to the medial edge of the iliacus muscle (the psoas tendon lies posteromedial to the iliacus muscle). Although the sartorius muscle might contribute to the flexion contracture, it is usually not tight. The anterior fascia of the thigh and the sartorius fascia might be tight. They might need to be released. The lateral femoral cutaneous nerve should be identified and protected before releasing these fasciae. The remaining flexion contracture is from the gluteus medius and minimus muscles and is addressed in the next step of the procedure (Fig. 5D).

Step 4: Abduction and External Rotation Contracture Releases

The abductor tendons (gluteus medius and minimus) insert into the greater trochanter and extend distally to become confluent with the quadriceps origin on the greater trochanter. The tendinous portions of both muscle groups can be sharply dissected and reflected together, maintaining the longitudinal continuity of the musculotendinous units. Neither muscle group can retract or shorten. With this step, the posterior aspect of the glutei is identified and followed to the posterior border of the greater trochanter. The posterior border of the vastus lateralis at the intermuscular septum is similarly identified and dissected free of the femur subperiosteally. This line is continued proximally along the posterior aspect of the greater trochanter. Because the tendinous covering of the trochanter is thin, it is important to peel a thin layer of cartilage with the flap. The flap of the conjoint gluteus-quadriceps tendon is sharply dissected and reflected from posterior to anterior off the trochanter and then anteriorly off the intertrochanteric line, leaving the anterior hip capsule intact. During this release, the piriformis tendon should be identified and released from its trochanteric insertion. This permits the femur to rotate internally. Once the abductor-quadriceps unit is free of the trochanter, the extension of the hip capsule to the acetabulum of the hip is evident. It is important not to release this capsule from the trochanter because doing so can lead to lateral subluxation. Because of the flexion contracture, femoral retroversion, and extension of the proximal femur, the greater trochanter is usually located very posterior and medial to the more prominent lateral/bump" (Fig. 5E and F).

Step 5: Proximal Femoral Osteotomy and Fixation

An arthrogram of the hip is next obtained. With the abduction, flexion, and rotation contractures all released, the femoral head and neck can be placed in neutral orientation to the pelvis by extending and maximally adducting the hip joint (Fig. 6). The fixation can be performed in one of two ways: (i) by using the hip plate method and (ii) by using the Rush rod method.

Hip plate method

With the hip plate method, the preferred implant is the pediatric sliding hip screw (Smith & Nephew, Memphis, Tennessee, U.S.A.). The first step is to place a guidewire from the tip of the trochanter to the center of the femoral head (Fig. 7A and B). A second reference wire is drilled up the femoral neck into the center of the femoral head. The neck reference wire should be at 15° to the trochanteric reference wire (Fig. 7C). The lag screw is inserted. The side plates are applied to the lag screw. With the use of a saw, a triangular segment of bone is removed from the side of the femur by making one cut parallel and one perpendicular to the plate. The width of the perpendicular cut is the same as the width of the shaft of the diaphysis of the femur.

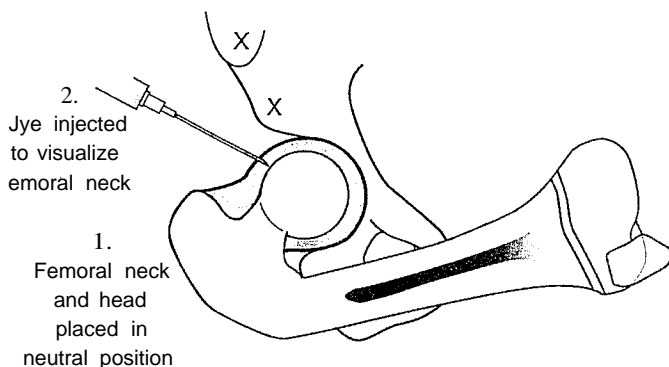

Figure 6 Arthrography performed, and hip placed in neutral position. Source: Figure copyrighted to the Rubin Institute for Advanced Orthopedics.

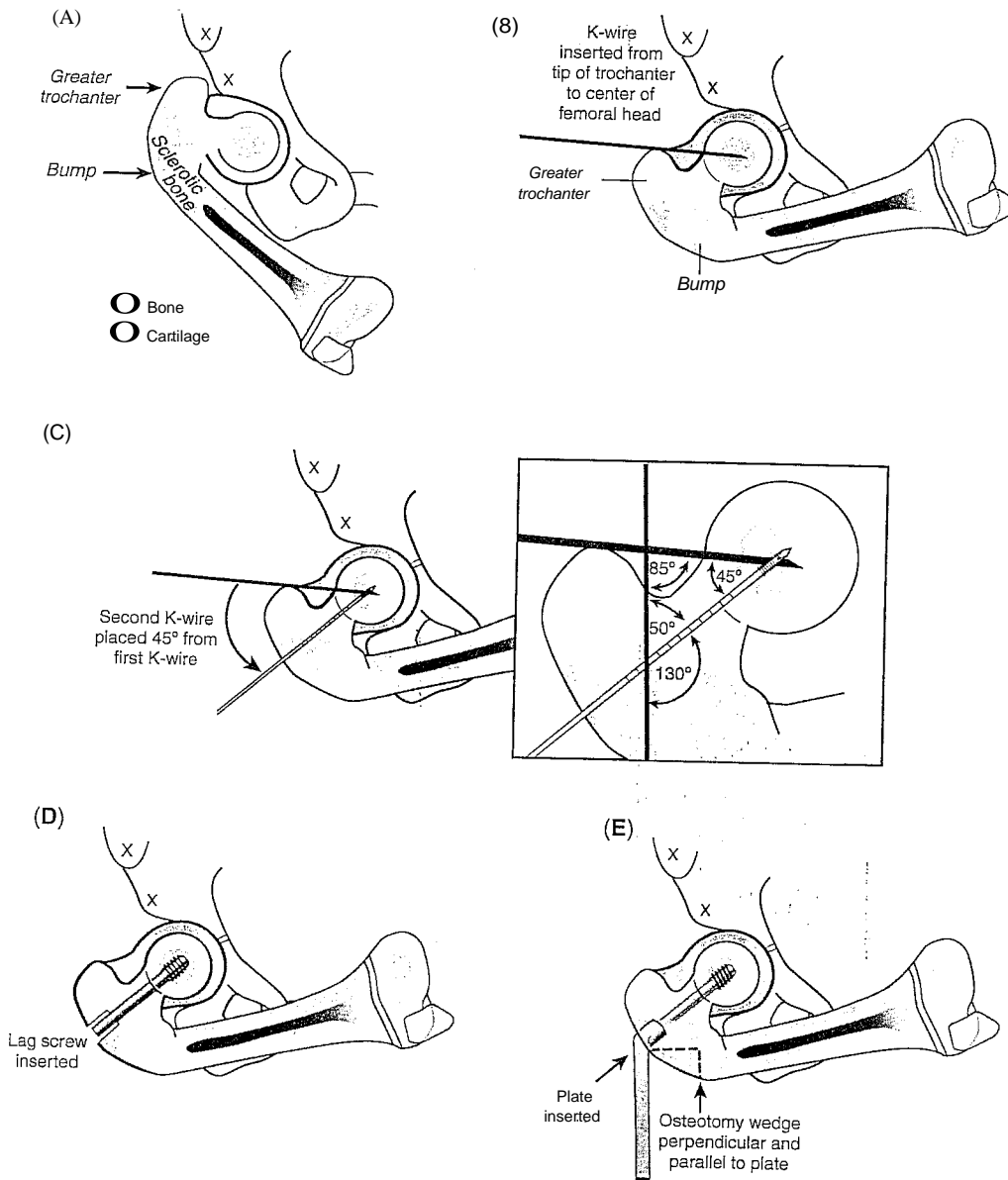

Figure 7 (A and B) After arthrography of the hip, a K-wire is placed from the tip of the greater trochanter to the center of the femoral head. (C) Second guidewire is placed into the femoral neck 45° from the initial guidewire. This will produce a 130° neck shaft angle after the osteotomy is completed. (D) Second guidewire is overdrilled, and the pediatric lag screw is inserted. (E) Side plate is applied and used as a guide for the initial bone cuts. A saw is used to remove a triangular segment of bone. The width of the perpendicular cut equals the diameter of the femoral diaphysis. (F and G) Second osteotomy is started at the parallel cut and directed distally in an oblique fashion. The third osteotomy is directed perpendicular to the long axis of the distal femoral segment and positioned to remove a 1- to 2-cm segment. (H-K) Compression screw is inserted into the pediatric lag screw. The femur is reduced to the plate and secured with screws. The most proximal screw should cross the osteotomy site into the medial buttress or up the femoral neck. Source: Figure copyrighted to the Rubin Institute for Advanced Orthopedics.

(Fig. 7D and E). Next, an osteotomy is made from the lateral end of the parallel cut, obliquely across the femur. A second osteotomy is made perpendicular to the femur 1 to 2 cm distal to the first cut. The segment that is removed is used as bone graft for the Dega pelvic osteotomy (Fig. 7F and G). The compression screw is next inserted to join the plate to the proximal femur. The distal femur is internally rotated and reduced to the plate. The plate is secured with screws. The most proximal screw crosses the osteotomy line into the medial buttress of bone left after removal of the triangular segment. Occasionally, it can be advanced parallel to the lag screw into the femoral neck and head. If this screw cannot be oriented to go across the femoral neck, a second screw should be inserted across the femoral neck for rotational control. This second head and neck screw is required in the hip with Type Ib CFD with delayed

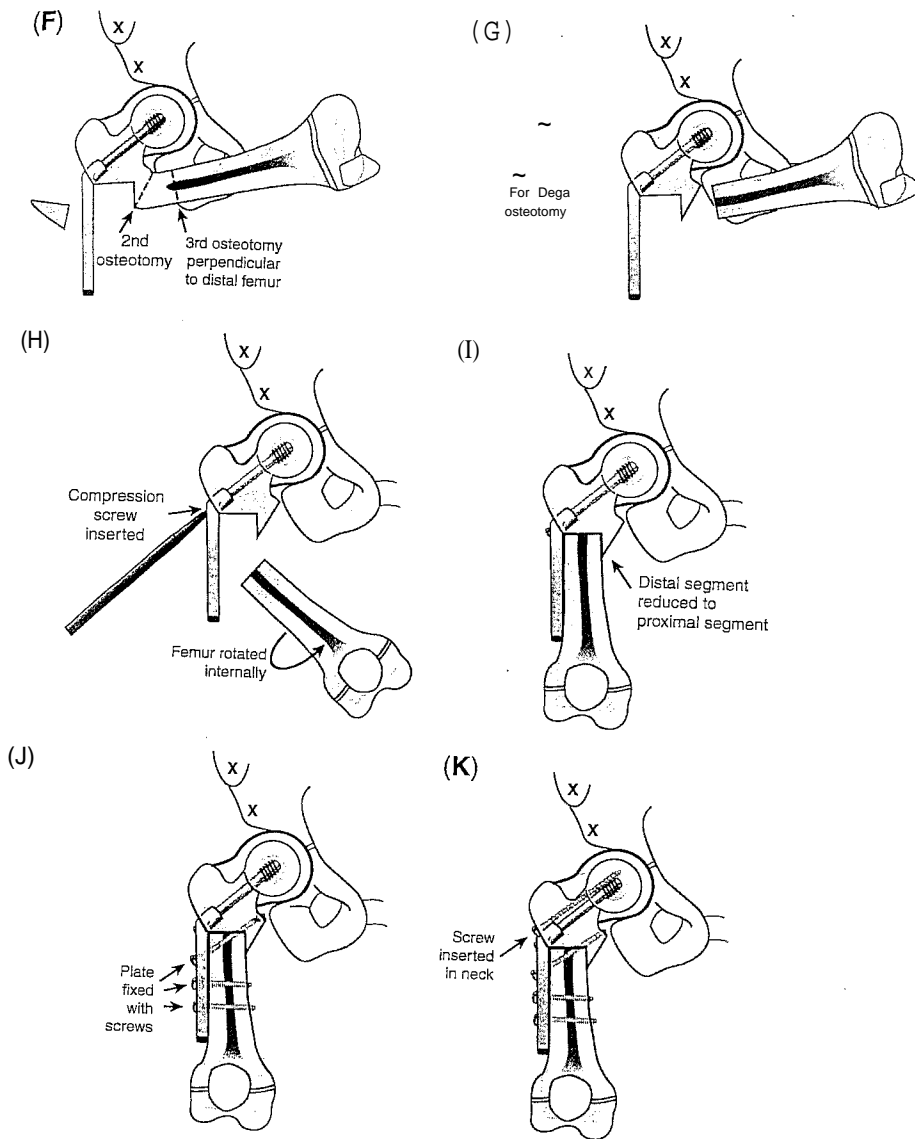

Figure 7 (Continued)

ossification of the femoral neck: With the subtrochanteric delayed ossification type, this is not necessary. With the subtrochanteric delayed ossification type, the lag screw does not need to cross the proximal femoral physis (Fig. 7H-K).

Rush rod method

With the Rush rod method, the first step is to place a guidewire from the tip of the greater trochanter to the center of the femoral head. A second reference wire is drilled at an 85° angle to the first wire, to create an MPFA of 84°. The second wire should be drilled from the lateral aspect of the femur to exit through the lateral aspect of the piriformis fossa (Fig. 8A). The wire passing through the piriformis is overdrilled with a cannulated drill. The diameter of the cannulated drill depends on the diameter of the Rush rod to be used for fixation. For a 3/8 (3mm) Rush rod, a 3.2-mm cannulated drill is used. Parallel and perpendicular cuts are made in the femur relative to the Rush rod, removing a triangular segment (Fig. 8B and C). A second osteotomy is performed 1 cm distal to the location of the triangular osteotomy. This creates a medial buttress of bone. A third osteotomy is performed 1 to 2 cm distal to the second osteotomy, removing a segment of bone. The medullary canal of the distal femur is drilled open with a solid drill bit of the same diameter as that which was used for the proximal end. The Rush rod is inserted into the proximal segment. The distal segment is reduced to the proximal segment and the Rush rod advanced across the osteotomy (Fig. 8E and F). For additional rotatory control,

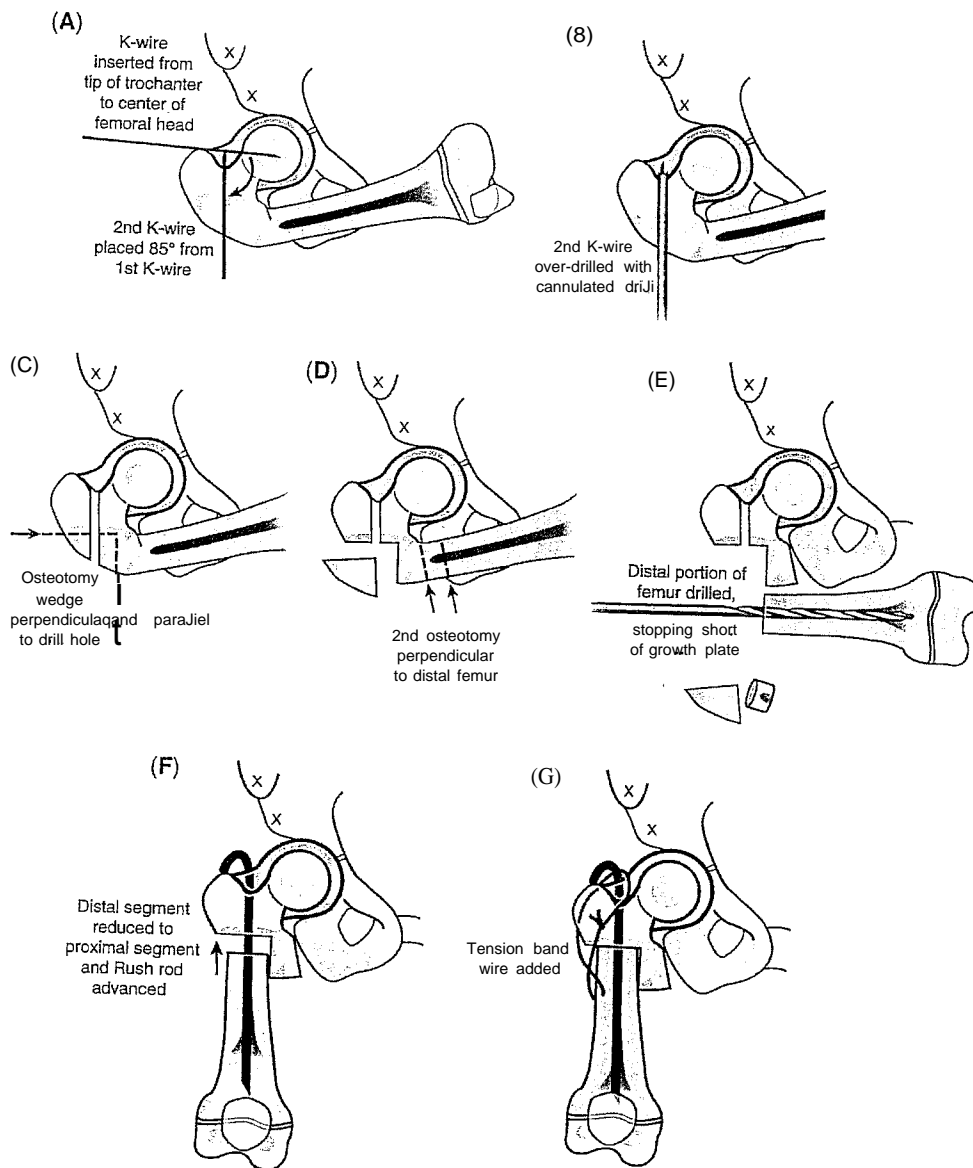

Figure 8 (A) Initial K-wire is placed from the tip of the greater trochanter to the center of the femoral head. The second guidewire is drilled from the lateral aspect of the femur, creating an 84° medial proximal femoral angle. (B and C) Second guidewire is overdrilled, creating the path for the rush rod in the proximal segment. Two cuts are made parallel and perpendicular to the rush rod path, removing a triangular segment of bone. (D) Second and third osteotomies are performed distal to the triangular osteotomy. These two osteotomies create a medial buttress proximally and remove a 1- to 2-cm segment of bone distally. This bone segment is later used for the Dega osteotomy of the pelvis. (E) Distal femoral canal is reamed with the same size drill as used in the proximal segment. (F) Rush rod is inserted from the proximal starting hole and advanced across the osteotomy site, reducing the femur. (G) Tension band wire is added for rotational control. The femur should be internally rotated and the anteversion of the hip confirmed with the use of fluoroscopy before the wire is tensioned. *Source:* Figure copyrighted to the Rubin Institute for Advanced Orthopedics.

a tension band wire is added. A 1.5-mm K-wire drill hole is created in the lateral cortex of the distal femur, from anterior to posterior, relative to the patella forward. An 1.5-gauge wire is then threaded through this hole and twisted in a figure eight fashion around the proximal end of the Rush rod (Fig. 5G). The plate method is most commonly used for hips with Type Ib CFD with delayed ossification of the femoral neck. The Rush rod method is most commonly used for hips with Type Ia or Ib CFD with subtrochanteric delayed ossification.

Step 6: Pelvic Osteotomy

Because of the extensive exposure, it is not necessary to split the iliac apophysis to perform the Dega osteotomy. The ilium is exposed by elevating and retracting the hip abductor muscles

from the lateral wall of the ilium, starting anterior at the anterior inferior iliac spine and working posteriorly. The dissection is continued back to the sciatic notch and distally toward the ischium. The dissection should not cross the triradiate cartilage. The osteotomy is curved along the lateral cortex from the anterior inferior iliac spine to triradiate cartilage posteriorly. The osteotomy is inclined toward the triradiate cartilage medially and should start 2 cm above the joint. The osteotomy is levered distally to cover the femoral head. The bone graft obtained from the femur is used to hold the osteotomy open and to level the source (Fig. 9).

Step 7: Tendon Repair and Closure

The conjoint abductor-quadriceps tendon is sutured directly into the cartilaginous greater trochanter with absorbable suture. This is performed with the femur in neutral abduction. The TFL is also sutured to the greater trochanter to augment the abduction strength of the hip. The incision is closed in layers, including Scarpa's fascia and subcuticular and skin layers. A suction drain is used because of the large anterior flap and is left in place until the draining stops, which can take several days. The patient is placed in a spica cast in full hip extension and neutral abduction and rotation for six weeks (Fig. 10).

INSTABILITY OF PATELLA OR TIBIA AND KNEE FLEXION CONTRACTURE

Instability of the patella necessitates performing a stabilizing-realigning procedure before lengthening. Isolated anteroposterior instability of the tibiofemoral joint without knee joint dislocation or rotatory subluxation does not need to be addressed before lengthening. Isolated subluxation or dislocation of the patella should be treated before lengthening. This reconstruction is based on a combination of elements from the Langenskiöld procedure (3) (designed for congenital dislocation of the patella), the MacIntosh procedure (4) (extra-articular reconstruction for anterior cruciate deficiency), and the Grammont procedure (5) (designed for recurrent dislocation of the patella). This knee stabilization procedure can be performed at the same time as the pelvic osteotomy or superhip procedure. When knee stabilization is performed together with a superhip procedure, the fascia lata is reflected from proximal to distal and is used for the ligamentous reconstruction.

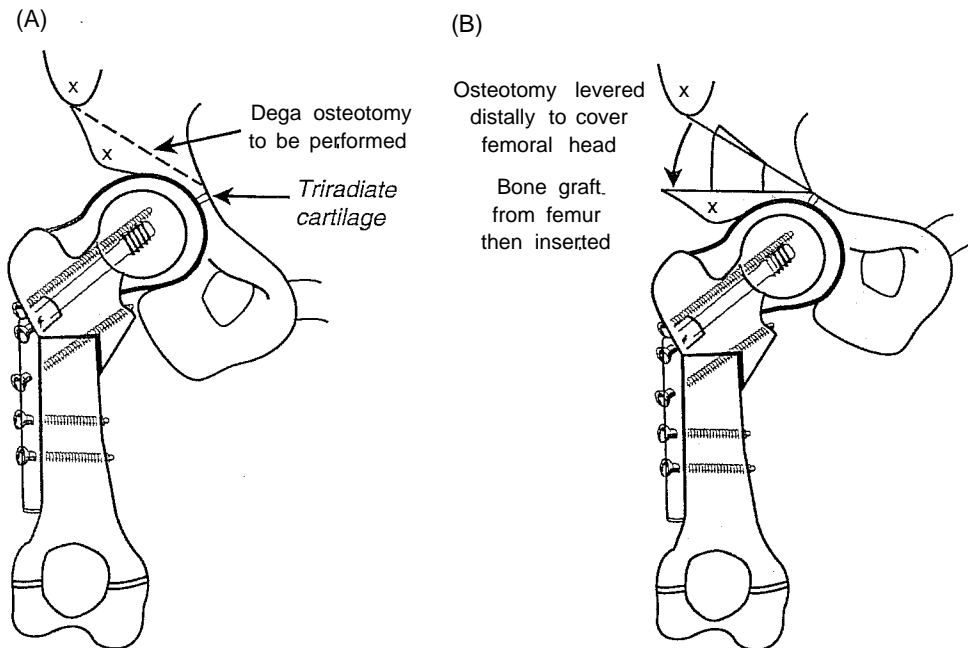

Figure 9 (A and B) Dega osteotomy is performed, exposing the outer table of the iliac crest under the abductor muscles without splitting the iliac apophysis. The osteotomy curves from the anterior inferior iliac spine to the triradiate cartilage along the lateral cortex of the iliac crest. The bone segment from the femur is used as the bone block for the Dega osteotomy. *Source:* Figure copyrighted to the Rubin Institute for Advanced Orthopedics.

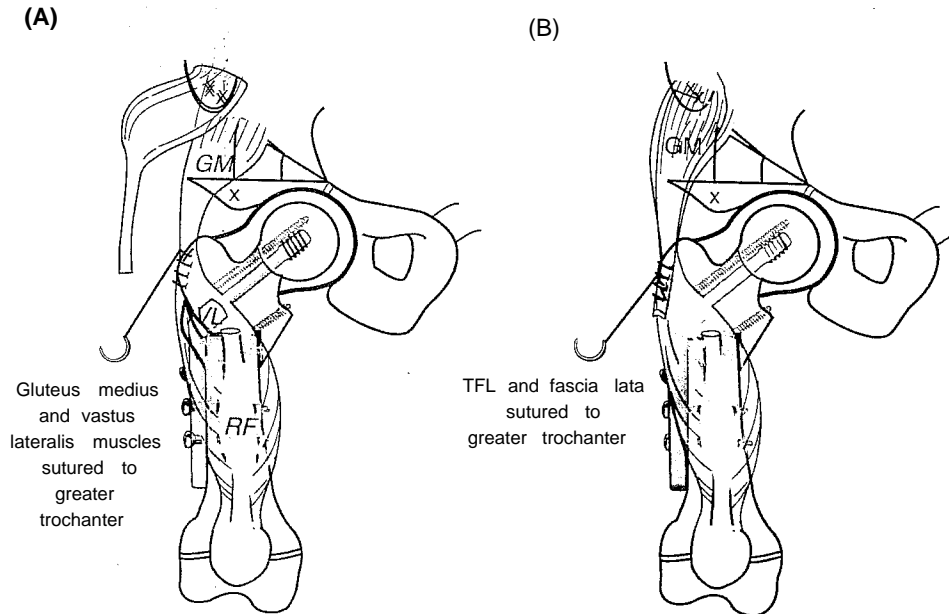

Figure 10 (A and B) Conjoint abductor-quadriceps tendon is sutured to the cartilaginous greater trochanter. The tensor lata muscle also is sutured to the greater trochanter to augment hip abduction strength. *Abbreviations:* 8M, gluteus medius; VL, vastus lateralis; RF, rectus femoris tendon; TFL, tensor fascia lata. *Source:* Figure copyrighted to the Rubin Institute for Advanced Orthopedics.

SUPER KNEE RECONSTRUCTION SURGICAL TECHNIQUES

The superknee procedure is a combination of patellar realignment with extra- and intra-articular knee ligament reconstruction. When needed, a posterior capsulotomy and knee flexor tendon release also are performed. Typically, the superknee consists of extra-articular or combined extra- and intra-articular anterior cruciate ligament (ACL) reconstruction (MacIntosh procedure), the reverse MacIntosh (Paley knee reconstruction) procedure (2), a posterior cruciate ligament (PCL) extra-articular reconstruction, the Grammont patellar tendon realignment, a lateral release of the patella, and a Langenskiöld procedure (2) for patellar reduction. In cases with actual posterior dislocation, intra-articular PCL reconstruction using the fascia lata is performed instead of or in combination with extra-articular PCL reconstruction.

Step 1: Fascia Lata Harvest

The knee is exposed through a long S-shaped incision. The anterior margin of the fascia lata and the posterior margin, where it blends with the intermuscular septum, are incised longitudinally. The fascia lata is transected as proximally as possible and reflected distally until its insertion onto the tibia (Fig. 11A and B).

Step 2: Preparation of Fascia Lata For Ligamentization

The fascia lata should be split into two longitudinal strips to make two ligaments. A Krackow whip stitch (8) is used to run a nonabsorbable suture from the free end of the fascia lata toward the Cerdy's tubercle in a tubular fashion (Fig. 12).

Step 3: Lateral Release and Grammont Patellar Tendon Realignment

In all cases, lateral release is performed. When patellar maltracking is more significant, a Grammont procedure is performed to medially transfer the patellar tendon. When fixed subluxation or dislocation is present, the modified Langenskiöld procedure is performed. The lateral capsule should be cut to, but not through, the synovium. The vastus lateralis

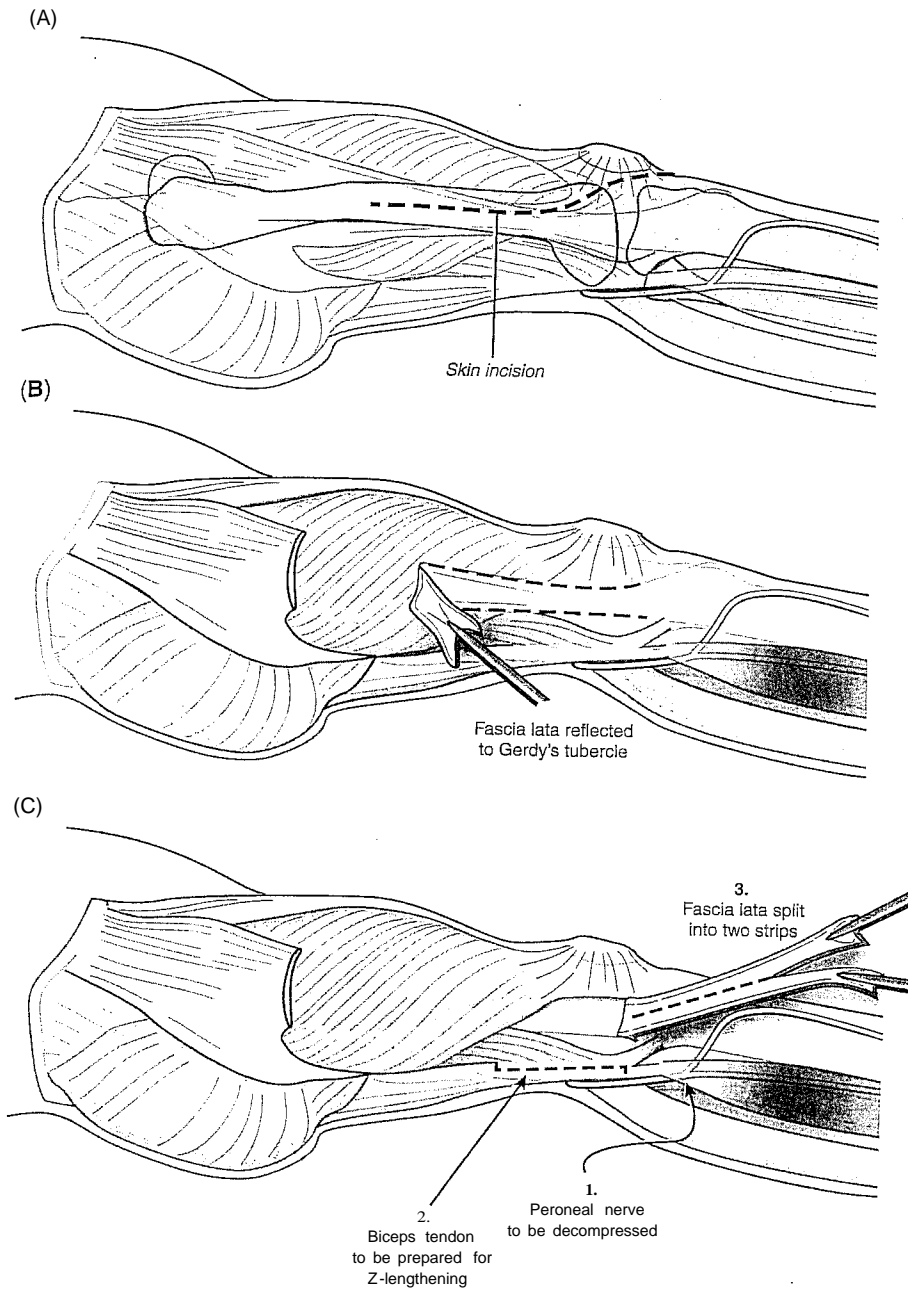

Figure 11 (A and B) S-shaped incision is performed on the lateral aspect of the distal thigh. The anterior and posterior margins of the fascia lata are identified and dissected proximally. The tensor fascia lata (TFL) is transected just distal to the TFL muscle belly. (C) The TFL is split longitudinally into two equal strips of tendon. Source: Figure copyrighted to the Rubin Institute for Advanced Orthopedics.

should be elevated off the intermuscular septum. If the patella is nonetheless tethered laterally by the vastus lateralis, its tendon is released from the patella and transferred centrally to the quadriceps tendon under minimal tension. The lateral release is extended distally to the lateral aspect of the patellar tendon. If the Grammont patellar tendon medialization is to be performed, the incision should be extended past the tibial tuberosity along the crest of the tibia, incising the proximal periosteum. A parallel periosteal, para tendinous deep incision is made medial to the patellar tendon. Sharp dissection is performed with a Beaver blade scalpel to elevate the patellar tendon off the tuberosity without peeling off cartilage. The periosteal extension of the tendon is elevated with the tendon so that the detached tendon remains tethered distally. The patellar tendon can then be displaced and sutured medially (Fig. 13).

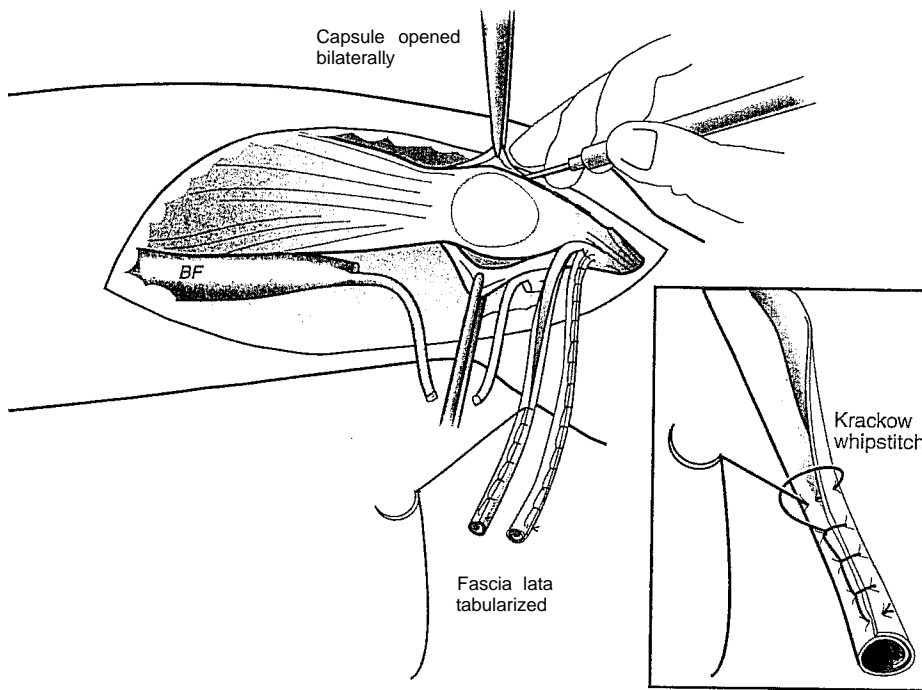

Figure 12 Tendons are then prepared with a Krackow whipstitch to form a tubular graft. *Source:* Figure copyrighted to the Rubin Institute for Advanced Orthopedics.

Step 4: Macintosh Intra- and/or Extra-Articular Anterior Collateral Ligament Reconstruction

The lateral collateral ligament (LCL) is identified. A tunnel is made under this ligament without entering the knee joint (Fig. 14A). Another tunnel is made subperiosteally, from anterior

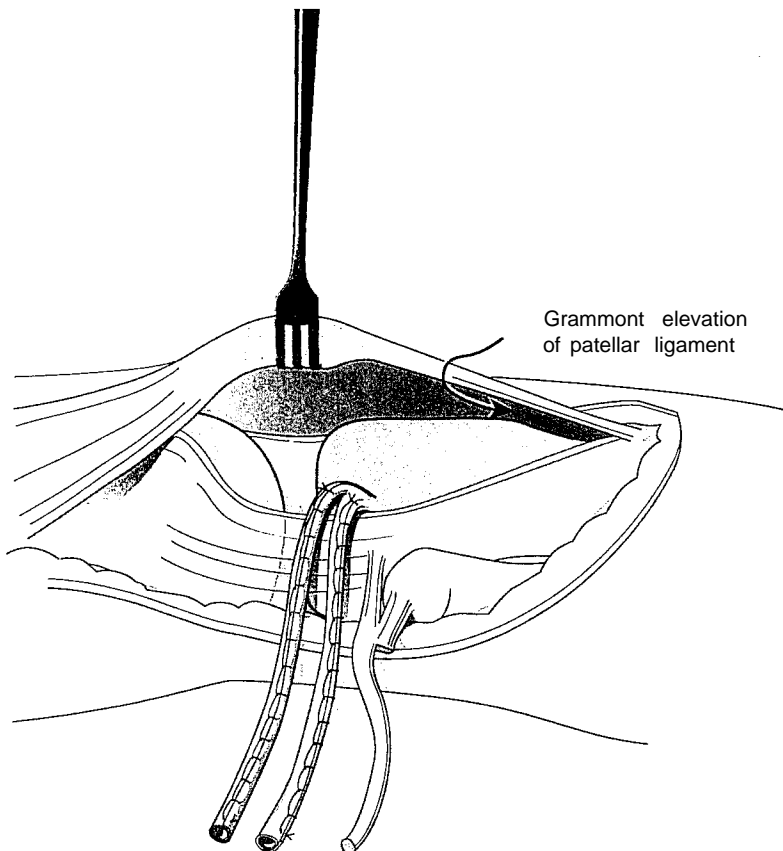

Figure 13 Grammont patellar tendon medialization is performed by incising the medial and lateral borders of the patella tendon past the tibial tubercle. The patella tendon is elevated off the tibial tubercle apophysis with an extension of periosteum that remains intact distally. The patella tendon can then be shifted medially. *Source:* Figure copyrighted to the Rubin Institute for Advanced Orthopedics.

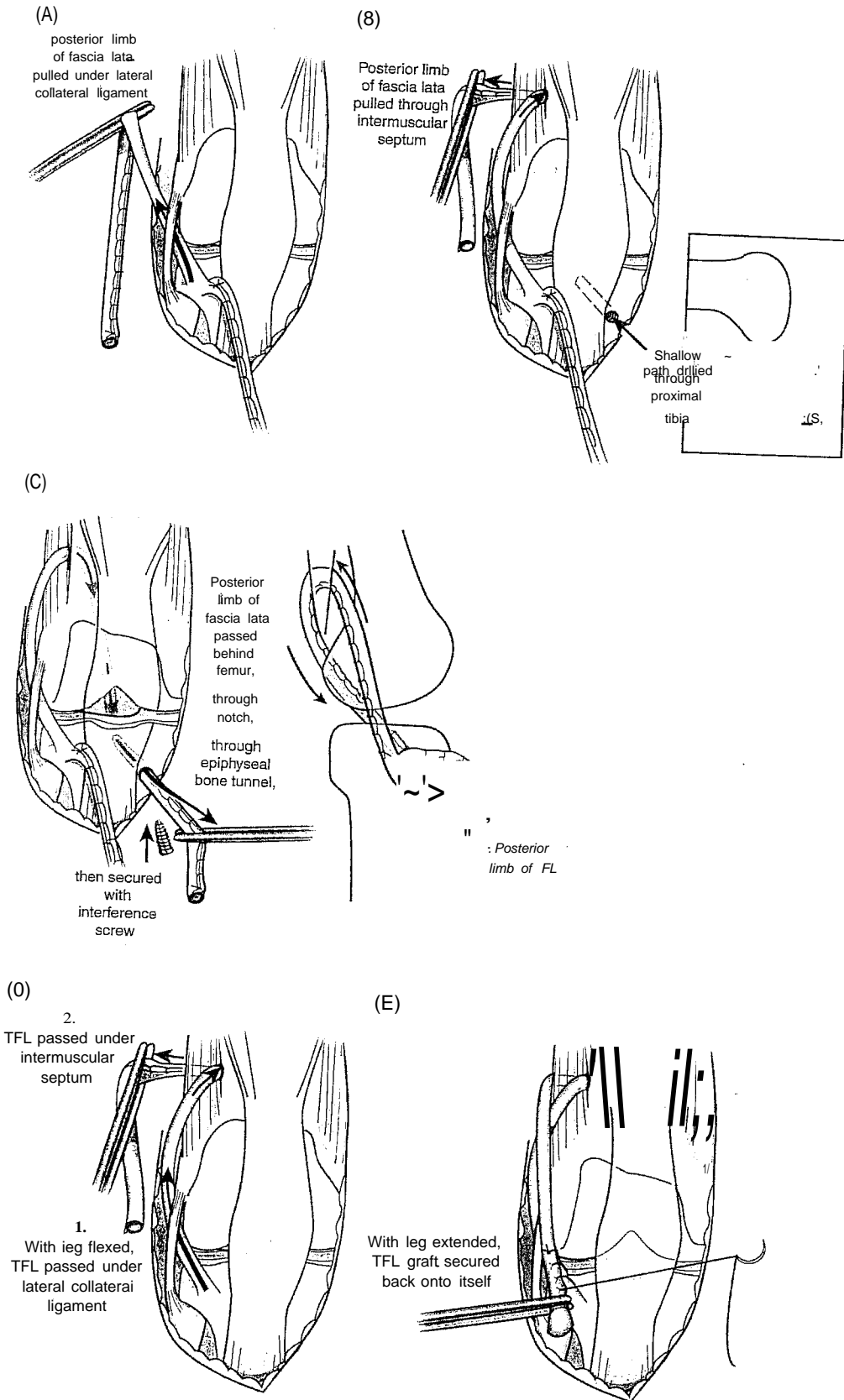

Figure 14 (Caption on facing page)

Figure 14 (Figure on facing page) (A) lateral collateral ligament (ICI) and the distal aspect of the posterior intramuscular septum are identified. The posterior limb of the tensor fascia lata (TFL) graft is passed under the ICI. (B) Posterior limb is passed through a subperiosteal tunnel under the lateral intramuscular septum. The graft enters the subperiosteal tunnel from the anterior aspect and heads distally toward the posterior knee joint capsule. Bony tunnel is created in the proximal tibial epiphysis (inset). A wire is placed into the epiphysis medial to the patella tendon. The wire is directed toward the lateral femoral condyle and exits the tibial epiphysis at the midpoint of the ossification center. This wire is overdrilled with the appropriate size cannulated drill, depending on the graft size. (C) Suture passer is inserted into the bony tunnel and retrieved at the posterior aspect of the knee with a curved clamp. After the graft has been passed under the ICI and through the subperiosteal tunnel, it is pulled through the posterior joint capsule and out the tibial epiphyseal tunnel. The graft is secured with a headless bioabsorbable interference screw. (D and E) Alternatively, instead of a combined intra- and extra-articular repair, an isolated extra-articular reconstruction can be performed. The graft is then tensioned with the limb in full extension, folded back onto itself, and secured with nonabsorbable suture. *Abbreviation:* FI, fascia lata. *Source:* Figure copyrighted to the Rubin Institute for Advanced Orthopedics.

and proximal to distal and posterior over the lateral intramuscular septum, of the femur, directed toward the posterior knee joint capsule. A hole in this capsule is made with a curved clamp. The posterior limb of the fascia lata is passed under the LCL. A bony tunnel is made in the proximal tibial epiphysis by using an ACL reamer over a wire. The wire is inserted from anteromedial to the patellar tendon to exit in the center of the tibial plateau. The diameter of the reamer is based on the outer diameter of the ligamentized posterior limb of the fascia lata (Fig. 14B). A suture passer is passed through the tibial epiphyseal tunnel, out the posterior capsule of the knee. The suture passer is retrieved from the posterior aspect of the knee with a curved tonsil clamp. The suture attached to the fascia lata is pulled through the knee and the bony tunnel via the suture passer. It is fixed to the tunnel by using a bioabsorbable headless screw (Arthrex, Inc., Naples, Florida, U.S.A.) (Fig. 14C). If only extra-articular ACL repair is needed, the fascia lata is looped back and sutured to itself and no tunnel is made (Fig. 14D and E). The ACL graft should be tensioned in extension to prevent a flexion contracture. The extra-articular portion self-tensions as the knee flexes. To prevent loosening, the graft can be reinforced and retensioned after fixation by passing a nonabsorbable suture through bone at the point at which the graft loops over the intermuscular septum. We currently prefer to use FiberWire (Arthrex) not only to anchor the ligament but also as a ligament augmentation device used in the Krackow ligamentization stitch described above. We prefer to combine extra-articular PCL reconstruction with an intra-articular "over the top" ACL repair.

Step 5: Extra-Articular Posterior Collateral Ligament Reconstruction (Reverse Macintosh)

The anterior skin flap is elevated off the knee and dissected and reflected medially until the entire vastus medialis can be visualized. The medial intermuscular septum, (very rudimentary) and the adductor magnus tendon are located posterior to the vastus medialis muscle. The anterior limb of the fascia lata is passed first under the patellar tendon and through a medial capsule tunnel. The graft is then passed through a subperiosteal tunnel around the adductor magnus tendon. It is then sutured to itself with nonabsorbable suture (Fig. 15). This extra-articular ligament should be tensioned with the knee in 90° of flexion to prevent an extension contracture. If intra-articular PCL reconstruction is preferred, the lateral head of the gastrocnemius muscle is released from the femur after the peroneal nerve is protected. The posterior epiphysis of the proximal tibia is identified to the midline. An anterior to posterior drill hole is made through the epiphysis, and the anterior limb of the fascia lata is passed from anterior to posterior, exiting near the midline posteriorly. Another drill hole through the medial distal femoral epiphysis is made, oriented from anteromedial to posterolateral. The ligamentized fascia lata is passed through the posterior capsule and into the medial femoral epiphyseal tunnel. It is fixed in place with a Biotenodesis absorbable screw (Arthrex).

Alternative Step For Patellar Realignment: Lanqenskiöld Reconstruction

If the patella is unstable with fixed lateral subluxation or dislocation, a modified version of the Lanqenskiöld procedure is performed before the ligament reconstruction (4). First, the capsule is separated from the patella and synovium medially and laterally. The synovium is also

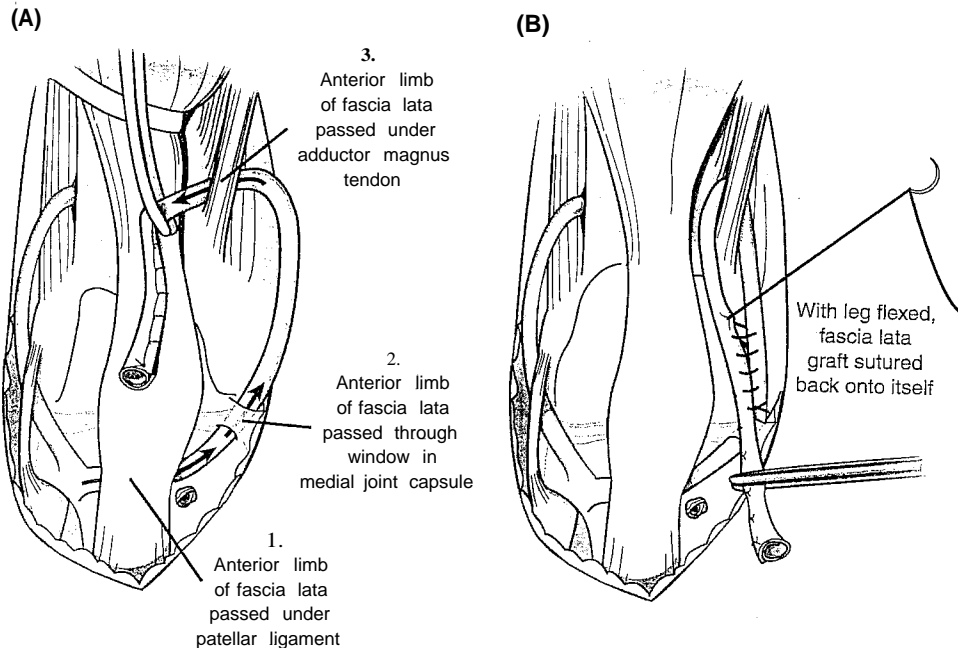

Figure 15 (A and B) Reverse Macintosh (extra-articular posterior collateral ligament) is performed by passing the anterior limb of the tensor fascia lata graft under the patella tendon and through a window created in the medial joint capsule. The graft is then passed through a subperiosteal tunnel under the adductor magnus tendon, looped back onto itself, and secured with nonabsorbable suture. *Source:* Figure copyrighted to the Rubin Institute for Advanced Orthopedics.

dissected free from the quadriceps muscle proximally and the patellar tendon distally (Fig. 16A and B). Once the synovium is completely free from its overlying tissues, it is cut from the patella circumferentially. The quadriceps and patellar tendons are left attached to the patella proximally and distally. The synovium is then a free layer with a patella-sized hole in it (Fig. 16C and D). This hole is sutured closed in a longitudinal direction, leaving the patella extra-articular. The medial gutter synovium and the synovium under the vastus medialis are dissected free from the medial capsule and retinaculum. The medial capsule is cut transversely, parallel to the joint line at its distal end. The patella tendon is elevated from the apophysis sharply after incising the medial and lateral borders of the tendon distally into the periosteum. The patella tendon is shifted medially at least 1 cm (Grammont procedure, Step 3) and is sutured in position at the end of the soft tissue reconstruction (Fig. 16E and F). A longitudinal incision is made in the synovium more medially, with the knee in extension. The patella is inserted into this new hole, and the synovium is sutured to the patella circumferentially. The medial capsule is advanced over the top of the patella and is sutured to its lateral border. The lateral capsule is left open (Fig. 16G-K). If the reverse Macintosh procedure is performed, the fascia lata should not be fixed in place until after the Langenski-Old repair is completed (Fig. 16L and M).

Alternative Step: Knee Flexion Contracture Release

If a knee flexion deformity of more than 10° is present, it can be treated by posterior capsular release. To avoid direct surgical and indirect stretch injury to the peroneal nerve, this nerve is identified and decompressed at the neck of the fibula. Next, the biceps tendon is Z-lengthened and the lateral head of the gastrocnemius muscle is released from the femur. The lateral capsule is identified and incised at the level just proximal to the joint line. The posterior capsule is dissected free of the posterior popliteal fossa contents, from a lateral to medial direction (Fig. 17A and B). A similar dissection is performed from the medial side after taking down the medial head of the gastrocnemius muscle. To expose the medial side, the anterior skin flap is reflected medially as thick as possible to preserve its circulation. The medial and lateral dissections are connected. Great care must be taken to avoid injury to the popliteal vessels, which lie adjacent to the medial half of the posterior capsule. The entire posterior capsule is then divided under direct vision from both sides (Fig. 17C and D). The knee FFD can be corrected by extending the knee.

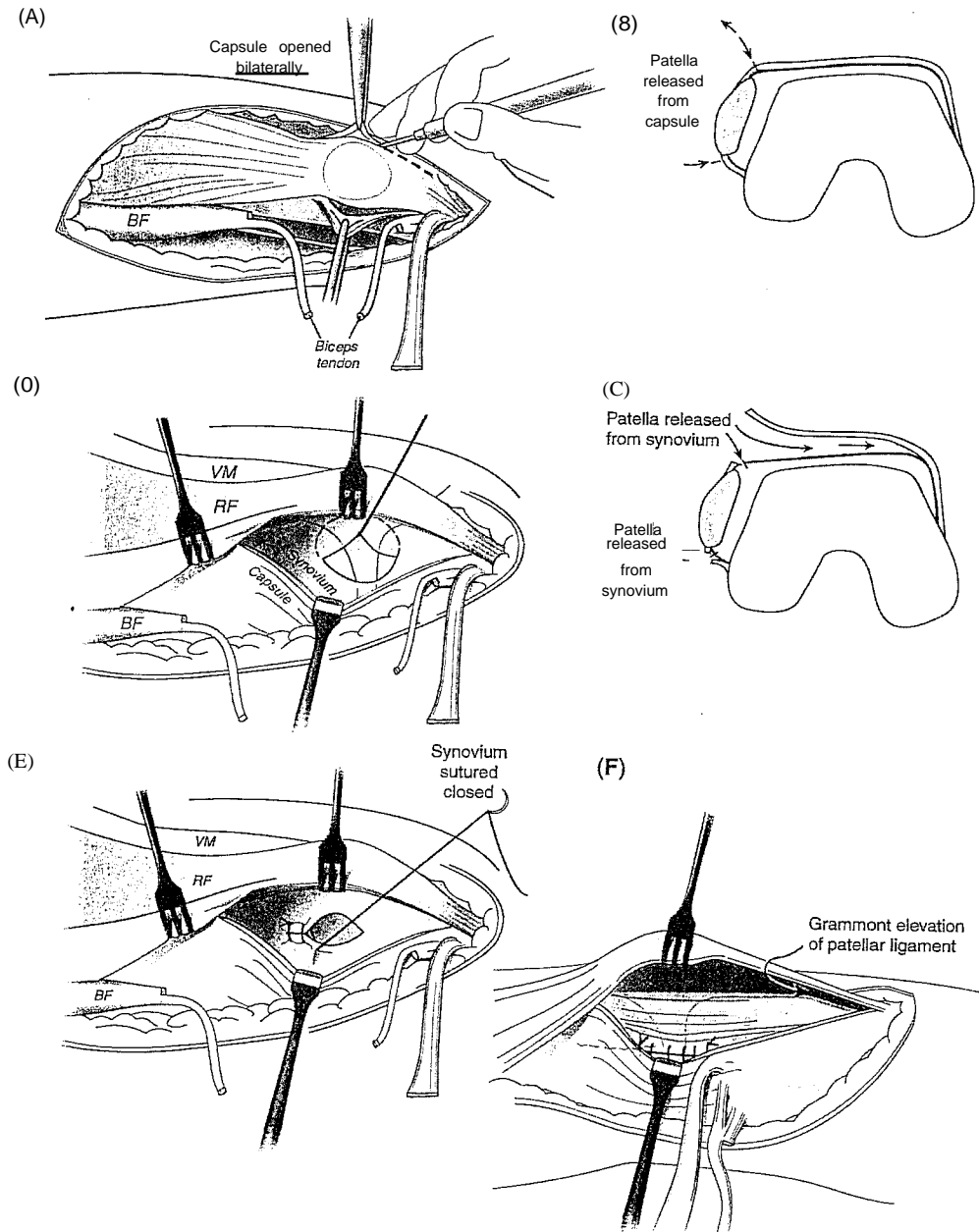

Figure 16 (A and B) Initial step in the modified Langenskiöld reconstruction is to perform a medial and lateral capsulotomy. The knee joint capsule is dissected away from the synovium medially and laterally. The synovium also is dissected free from the quadriceps tendon and the patella tendon. (C and D) Synovium is released from the patella circumferentially, leaving the quadriceps and patella insertions intact. (E and F) Hole in the synovium is closed longitudinally with absorbable suture, leaving the patella with the quadriceps and patella attachments extra-articular. The Grammont elevation and Grammont medial patellar tendon shift are then performed (see Step 3 and Fig. 13). (G-K) Knee is positioned in full extension, and the new position for the patella is marked on the synovium. A longitudinal incision is created in the synovium. The synovium is sutured to the patella in a circumferential fashion. The medial capsule is advanced and sutured onto the lateral side of the patella. The lateral capsule is not repaired. (L and M) If an extra-articular posterior collateral ligament (reverse Macintosh) is performed, the Langenskiöld reconstruction is completed before the ligamentous reconstruction. Tensor fascia lata graft passes through the advanced medial capsule is sutured onto itself. *Abbreviations:* m, muscle; VM, vastus medialis; RF, rectus femoris tendon; SF, biceps femoris muscle. *Source:* Figure copyrighted to the Rubin Institute for Advanced Orthopedics.

The collateral ligaments are left intact. The biceps femoris Z-lengthening is repaired (Fig. 17E and F). In addition, if a muscular contracture of the medial hamstrings is present, a small posteromedial incision can be made to recess the semitendinosus and semimembranosus tendons.

The above hip and knee procedures are termed "preparatory surgery for lengthening" and must be performed before femoral lengthening. Preparatory surgery prevents complications that

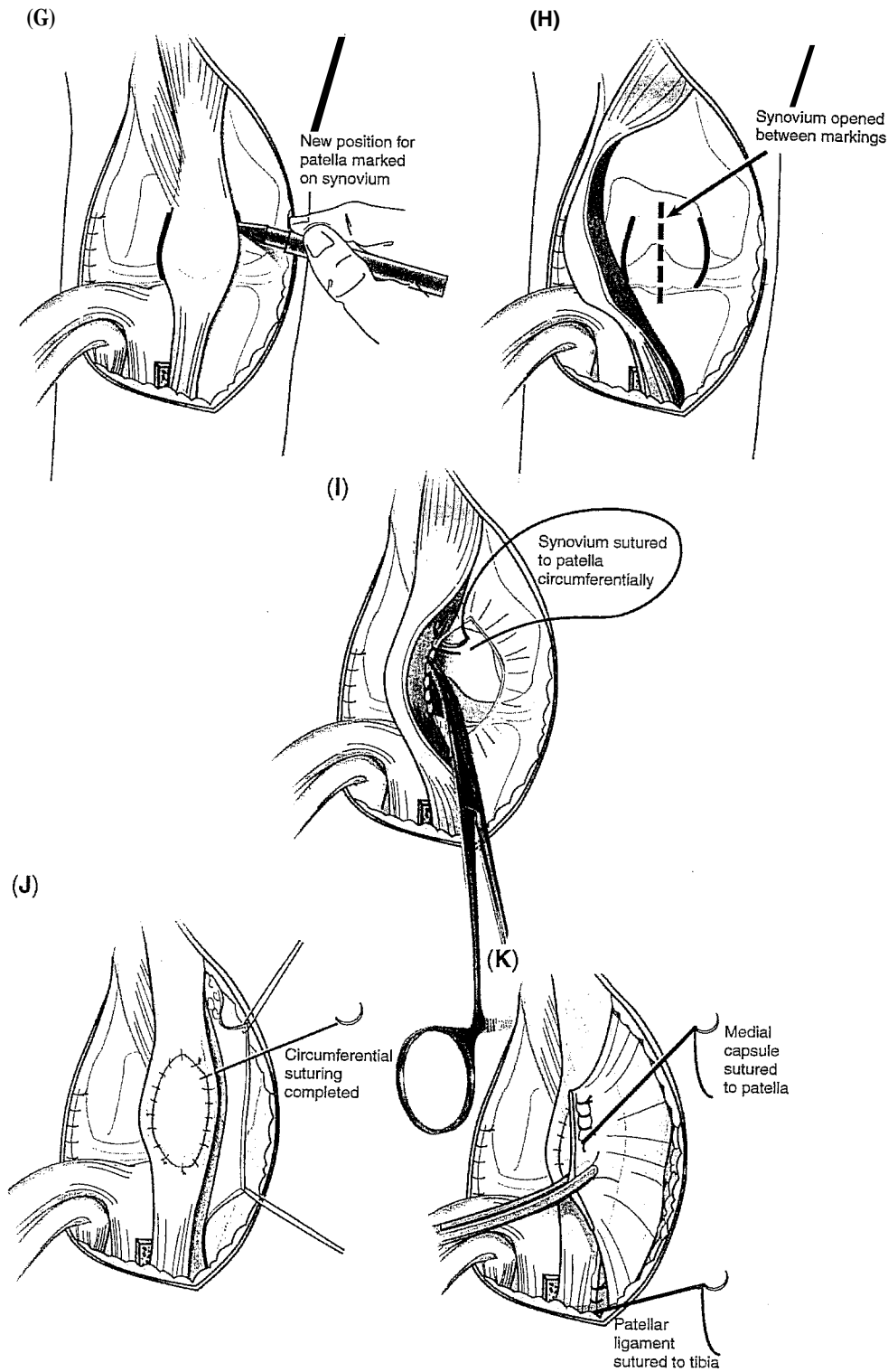

Figure 16 (Continued)

could occur during the lengthening process. The pelvic osteotomy prevents hip subluxation/dislocation. The proximal femoral reconstruction (superhip) prevents worsening of the coxa vara deformity, proximal migration of the femur, and dislocation of the hip. The patellar realignment prevents patellar dislocation and extension knee contracture. The ACL-PCL reconstruction prevents knee subluxation/dislocation and late problems of knee instability in adolescence. The fascia lata excision prevents posterolateral rotatory subluxation of the knee, knee contractures, increased pressure on the joint and physis, and valgus deformity of the knee.

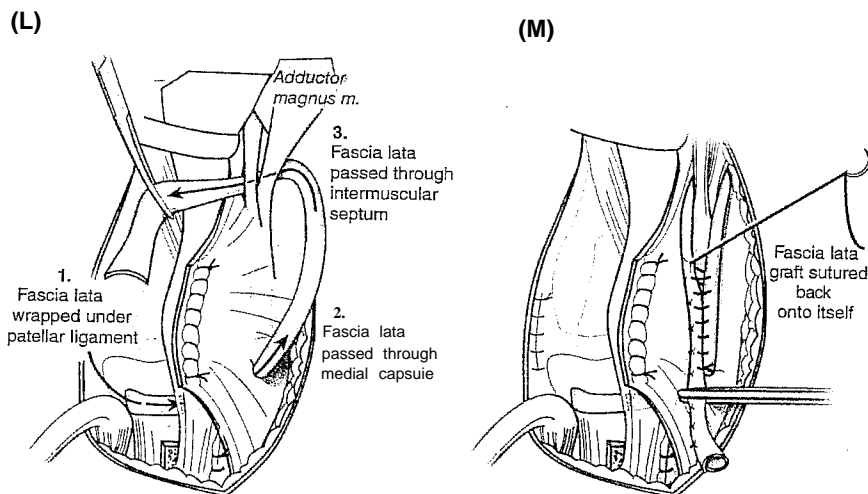

Figure 16 (Continued)

FEMORAL LENGTHENING OF TYPE 1 CONGENITAL FEMORAL DEFICIENCY Choice of Osteotomy Level for Lengthening of the Congenitally Short Femur

With Type 1 CFD, it is preferable to lengthen the femur by using a distal femoral osteotomy. Distal osteotomies have a broader cross-sectional diameter for better bone formation and are less prone to the deforming forces from the adductors and hamstrings. Distal osteotomy lengthening is closer to the knee joint and therefore has greater effect on knee range of motion and on knee subluxation. Proximal osteotomies have less effect on knee range of motion but are more prone to poor bone formation. Also, when using the external-fixator-only method of bone lengthening, a higher rate of fracture after removal of external fixation is encountered in the proximal lengthening groups when compared with the distal lengthening groups. Proximal osteotomies should be reserved for the technique of lengthening over nails (LON) because the nail prevents deformation of the proximal femur, both during and after removal of fixation, prevents fracture, and allows early removal of the external fixator despite incomplete consolidation of the regenerate bone.

Associated deformities of the hip and knee need to be considered when choosing the level of osteotomy. The external rotation deformity of the femur associated with CFD should be corrected at a proximal osteotomy level. The quadriceps muscle is in a normal relationship to the knee joint and originates distal to the level of a proximal femoral osteotomy. Therefore, a proximal femoral internal rotation osteotomy does not disturb the quadriceps orientation relative to the knee joint. In comparison, a distal osteotomy leaves the bulk of the quadriceps muscle attached proximally in a lateral position and rotates the knee medially, increasing the effective Q angle and the tendency to laterally displace the patella (Fig. 18). A varus deformity of the hip or the proximal diaphysis is corrected by using a proximal osteotomy, and a valgus deformity of the distal femur is corrected by using a distal osteotomy. These deformities can be addressed at the time of the lengthening by performing acute correction with either a proximal or distal osteotomy, as noted.

The proximal femoral osteotomy should be used for varus correction or derotation. Lengthening should not be performed through the proximal osteotomy because of the poor regenerate bone formation. In cases in which a proximal femoral osteotomy is performed, a distal osteotomy is also performed for lengthening.

The distal femoral osteotomy is used to correct the distal femoral valgus deformity (Fig. 19). This region of the femur has a wider cross-sectional area, producing a regenerate bone that is wider, stronger, and subjected to less bending forces than in the proximal femur.

In older children with wider medullary canals (> 7 mm), the LON technique can be performed (9,10). A proximal osteotomy can be used for lengthening with this technique because it involves little risk of refracture with a rod in the medullary canal. A greater trochanteric starting point is used, along with an appropriate size Rush rod with a proximal bend (9). Fixator-only lengthening is the method used for the first lengthening. The LON technique or fully

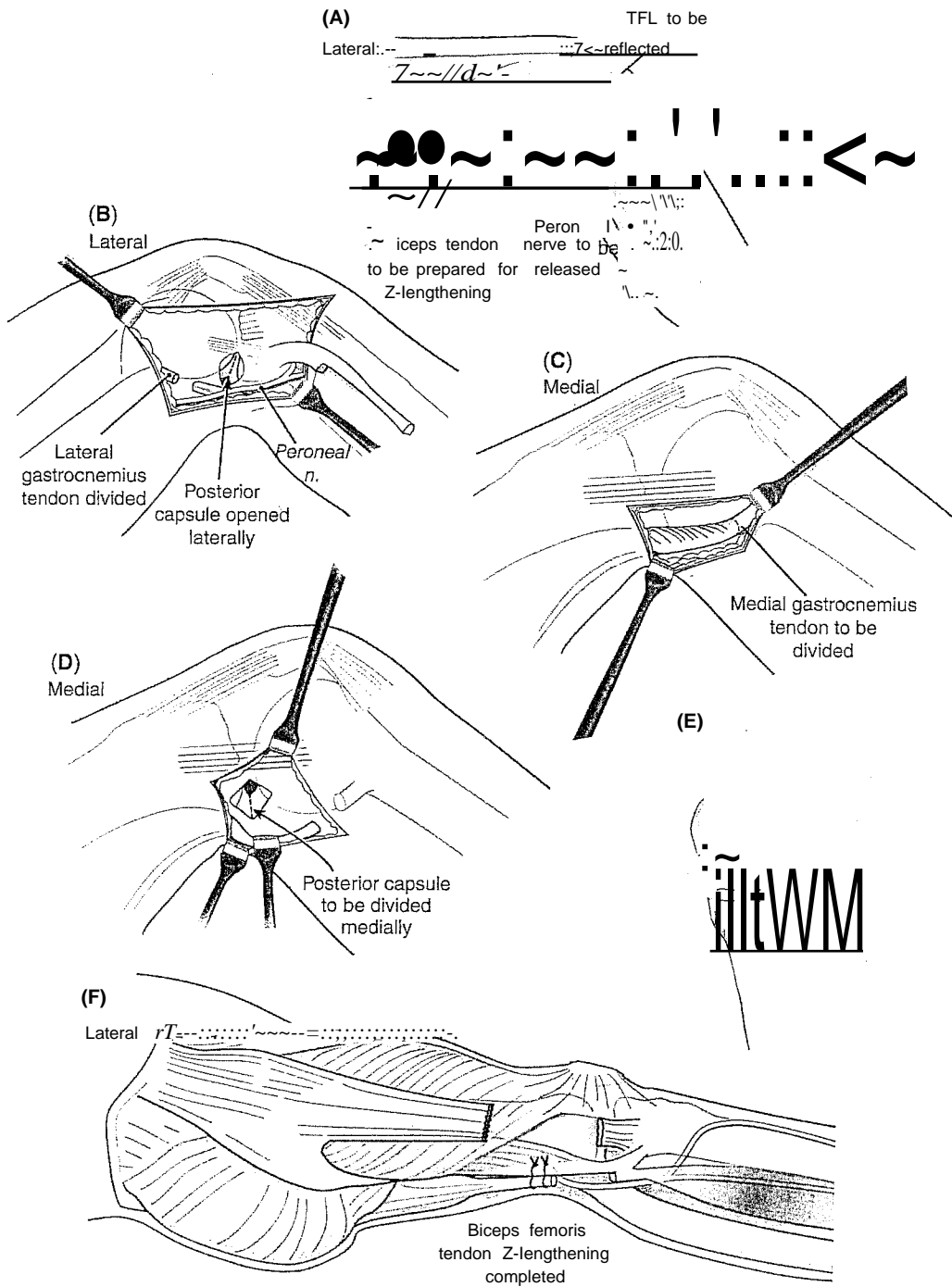

Figure 17 (A and B) Knee flexion contracture release is performed through the same S-shaped lateral incision as previously described. The peroneal nerve is identified and decompressed, and then a Z-lengthening of the biceps femoris tendon is performed. The lateral collateral ligament and lateral gastrocnemius tendon are identified. The lateral head of the gastrocnemius muscle is released, and the posterior joint capsule is identified. The posterior joint capsule is incised proximal to the joint line. (C and D) Medial side of the knee joint is exposed either by dissecting the anterior flap medially or through a separate medial incision. After the exposure is completed, the medial gastrocnemius muscle is released and the posterior capsule identified. Again, the posterior capsule is dissected free from the popliteal fossa contents and incised proximal to the joint line. The posterior capsule is divided under direct visualization from both the lateral and medial dissections. (E and F) Knee flexion deformity can then be corrected by gently extending the knee. The biceps femoris tendon lengthening is then repaired. *Abbreviation:* n, nerve. *Source:* Figure copyrighted to the Rubin Institute for Advanced Orthopedics.

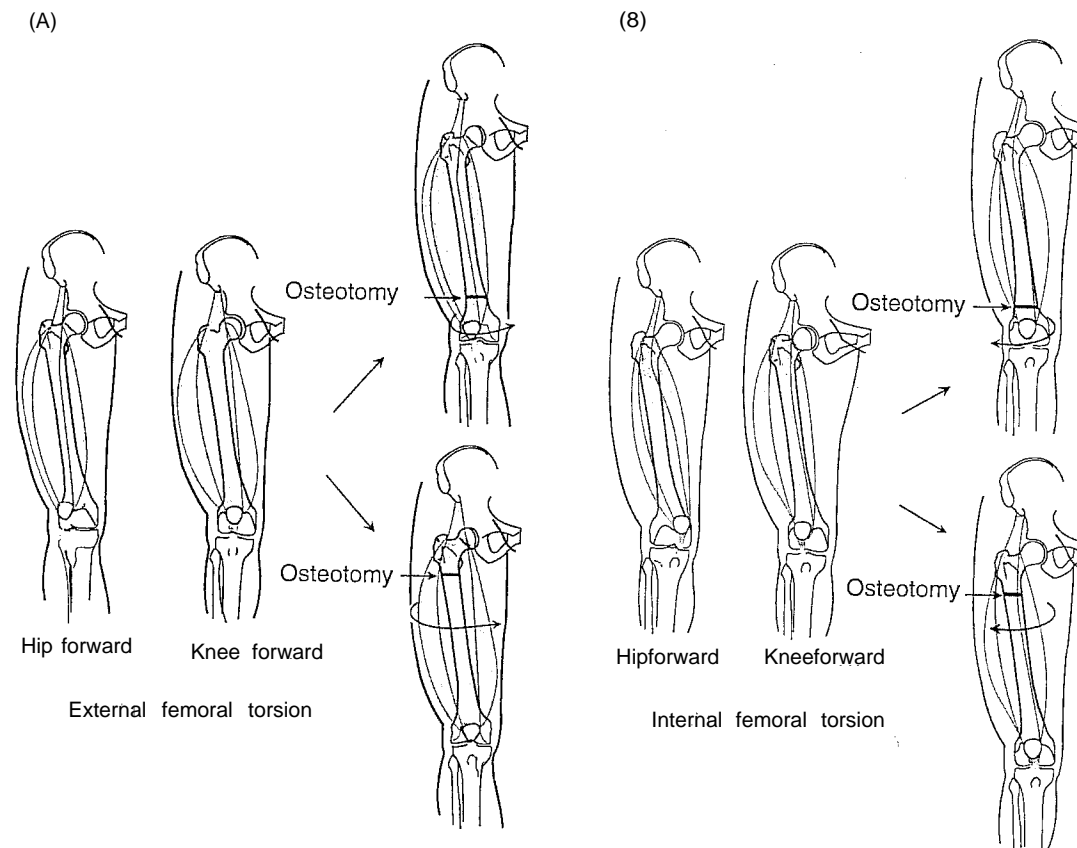

Figure 1B (A and B) Congenitally short femur with marked external rotation deformity. Femur is derotated through a proximal osteotomy (*lower right*). Femur is derotated through a distal osteotomy (*upper right*). Modified from Ref. 7.

implantable lengthening with an intramedullary lengthening device [e.g., intramedullary skeletal kinetic distractor (ISKD) (11)] is often the method for the second or third lengthening if the anatomic dimensions permit. The LON method allows the fixator to extend across the knee joint with hinges, as does the fixator-only method. The implantable lengthening nail method must rely on splinting the knee in extension between therapy sessions to prevent knee subluxation. The ISKD lengthener, currently the only implantable lengthening nail approved by the U.S. Food and Drug Administration, often lengthens faster than desired. This increases the risk of subluxation. To use this device safely, we limit the total amount of lengthening to no more than 5 cm. Most knee subluxations do not occur before 4 cm of length has been achieved. With external fixation-only lengthening, lengthening 8 cm and more can be performed safely as long as the knee range of motion can be maintained from full extension to more than 45° of flexion. With implantable lengthening, more frequent, shorter lengthenings are accepted as a tradeoff for the convenience and advantages of not wearing an external fixator. LON offers the advantages of both, by shortening the external fixation time while permitting as much lengthening with knee protection as with the external-fixation-only method.

Soft Tissue Releases for Lengthening

Soft tissue releases are essential in conjunction with lengthening to prevent subluxation and stiffness of the knee and hip. If a superhip or superknee reconstruction has already been performed, soft tissue releases that were addressed at the previous surgery do not need to be repeated. Soft tissue releases are performed at the time of the index procedure.

Before surgery, the range of motion of the hip and knee should be evaluated and the presence of contractures identified. The muscle lengthening tests are the straight leg raising test (popliteal angle) for the hamstrings, the prone knee flexion test (Ely test) for the rectus femoris, and hip abduction range for the adductors. If a popliteal angle of more than 0° or a prone knee bend less than the supine knee bend (or pelvic flexion with prone knee

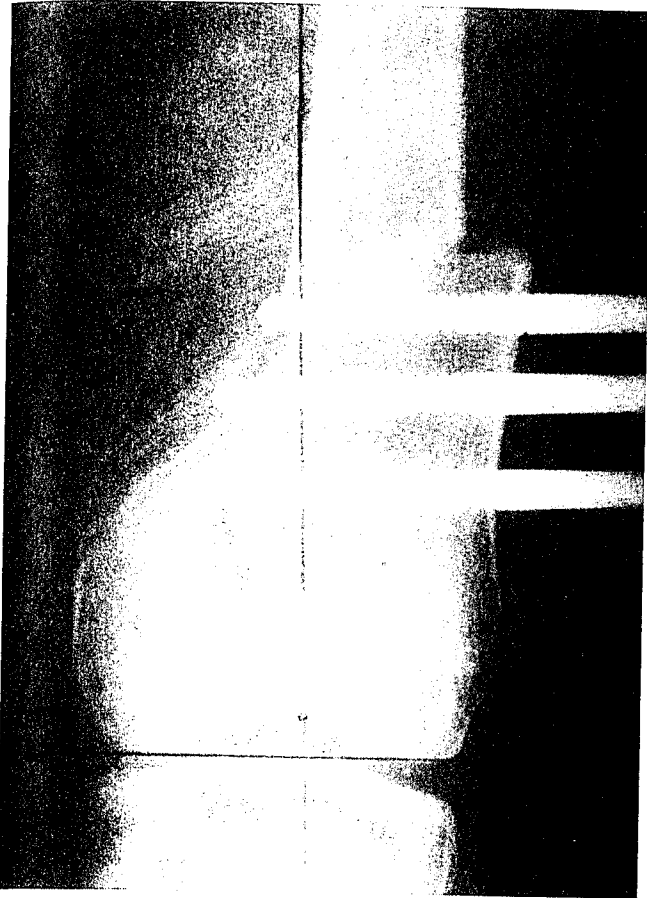

Figure 19 Radiograph shows acute valgus correction performed at the osteotomy site for lengthening.

flexion-positive Ely test) is present, the hamstrings and rectus femoris, respectively, are tight and will lead to contractures during lengthening. The medial and lateral hamstrings should be recessed proximal to the knee, to reduce the popliteal angle to 0° . The rectus femoris tendon should be released off the anterior inferior iliac spine through a small anterior inguinal incision. Finally, if hip abduction is limited, especially with proximal lengthening, percutaneous adductor tenotomies should be performed of the adductor longus and gracilis tendons. During lengthening, if a severe adduction contracture develops or the hip begins to subluxate, a more extensive open adductor release (including the adductor brevis) is performed. Woolf and Gross (12) have also recommended distal release of the adductor magnus tendon.

If the fascia lata has not been excised, a release is performed. The entire fascia lata, including the posterior intermuscular septum, is transected at the level of the proximal pole of the patella. The lateral biceps can also be safely recessed through the same incision, if needed. The incision for this combined release of the biceps and fascia lata should be made laterally over the top of the intermuscular septum. The proximal TFL is occasionally released as it passes over the greater trochanter. This is rarely performed at the index procedure. This procedure is usually performed in a delayed fashion to treat hyperlordosis of the lumbar spine, hip flexion contracture, and hip abduction contracture resulting from the lengthening. The proximal fascia lata can be released through the same small incision used to release the rectus femoris tendon. For distal femoral lengthening, it is not necessary to release the hip adductors. Again, proximal femoral lengthening usually requires hip adductor release in a delayed fashion unless a contracture is present at the index surgery.

Botulinum toxin is injected in the quadriceps muscle at the time of surgery. This reduces muscle spasm and pain, allowing improved knee flexion range of motion during physical therapy (13).

Knee Instability Consideration

All cases of CFD can be assumed to have hypoplastic or absent cruciate ligaments, with mild-to-moderate anteroposterior instability. Some knees also have mediolateral and torsional

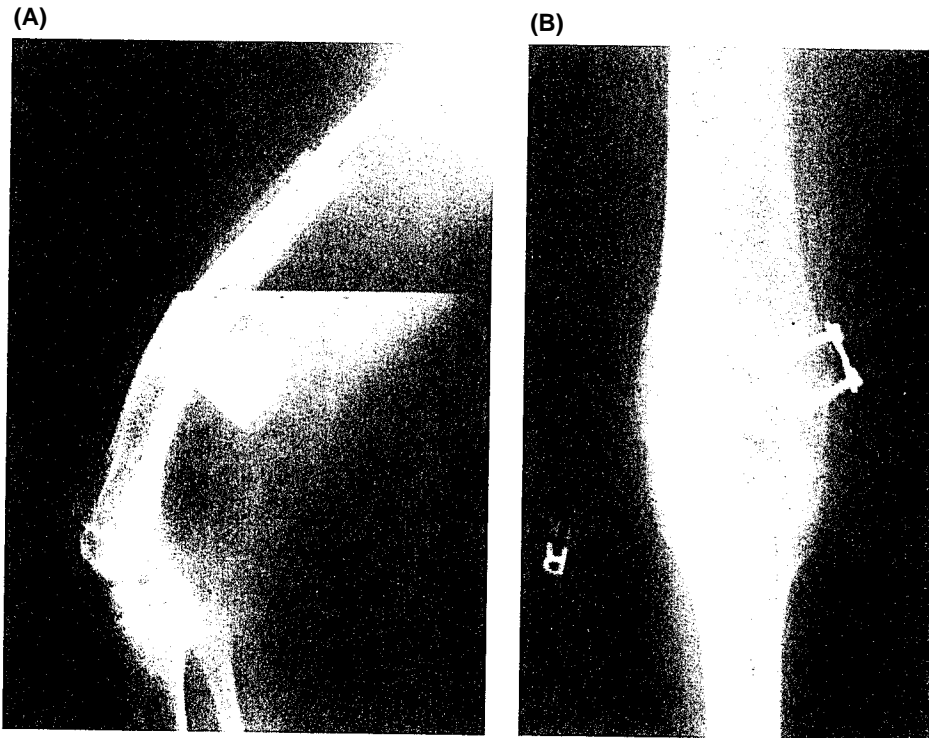

Figure 20 Patient with congenital femoral deficiency undergoing femoral lengthening with an intramedullary lengthening nail. Lateral view (A) and anteroposterior view (B) radiographs show knee flexion contracture with concurrent posterior-lateral subluxation. Aggressive therapy and soft tissue releases can be used to solve this complication. If an external fixator is being used for lengthening with this complication, lengthening is halted immediately. Fortunately, the intramedullary nail had completed the programmed 5 cm of lengthening at the time this radiograph was obtained.

instability. Despite this; the knee is shown to have normal tracking preoperatively; leaving no indication to perform ligamentous reconstruction. The significance of this knee instability is the tendency of the knee to subluxate with lengthening. Knee subluxation with lengthening is usually posterior or posterolateral (posterior plus external rotation of the tibia on the femur) (Fig. 20). Rarely; this subluxation can be anterior. Knee extension maintains a reduced knee position. Therefore; to prevent posterior subluxation; some authors recommend splinting the knee in extension throughout the distraction phase (14). This promotes knee stiffness while protecting the knee from subluxation. The knee should be protected by extending the fixation to the tibia with hinges. The hinges permit knee motion while preventing posterior and anterior subluxation. This hinge configuration is easily performed with the Ilizarov circular fixator (Fig. 21). More recently; a technique to extend the fixation to the tibia with a hinge by using a monolateral external fixator has been developed (Fig. 22).

A less common pattern of knee instability is anterior subluxation/ dislocation of the tibia on the femur. This occurs when the knee is fully extended. This instability pattern is partly caused by an anterior deficiency of the distal femur. Although one treatment option is extension osteotomy of the knee; the superknee procedure is our recommended treatment to avoid loss of knee flexion and to provide the most normal anatomy and stability of the knee.

Distal Femoral Lengthening: Ilizarov Fixator Technique

The necessary soft tissue releases are performed first as described above. If a proximal femoral derotation, valgus; and/ or extension osteotomy is needed, the proximal pin is inserted into the proximal femur with the hip in the position in which it will lie after the correction. For example, with correction of varus; flexion; and external rotation, the femur should be externally rotated and crossed over the other thigh to adduct and flex the hip. This places the hip in the true neutral position. The first half-pin is inserted from lateral to medial in the frontal plane; parallel to the line from the tip of the greater trochanter to the center of the femoral head (proximal femoral joint orientation line) (Fig. 23). The plan is to attach the proximal arch

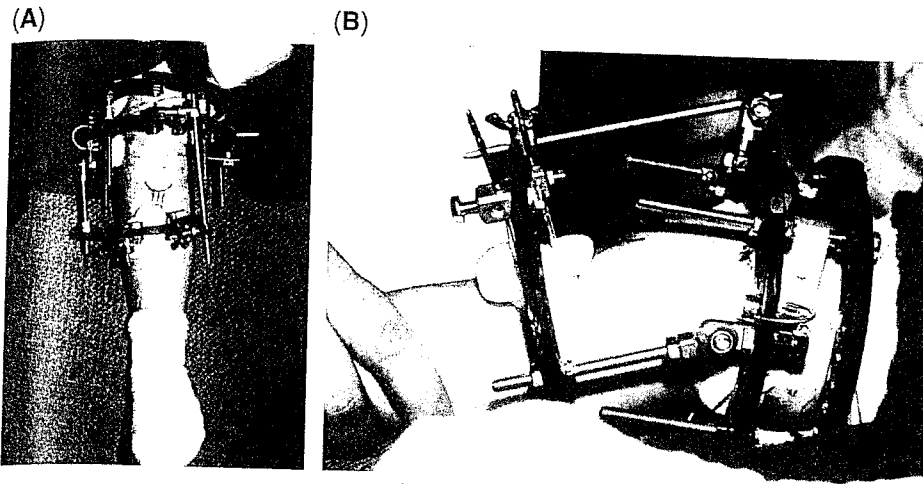

Figure 21 (A and B) Clinical photographs show an Ilizarov external fixator being used for femora/lengthening in a patient with congenital femoral deficiency. Note the distal femoral ring bridged across the knee joint with hinges to prevent subluxation and dislocation.

parallel to the proximal femoral joint orientation line, the middle ring perpendicular to the mechanical axis of the femoral diaphysis (7° to the anatomic axis), and the distal ring parallel to the knee joint line. After the osteotomies, when all the rings and arch are parallel, the mechanical axis of each segment will be aligned and the joint orientation of the hip and knee will be parallel. A second proximal half-pin is inserted on the proximal arch from 30° anterolateral to

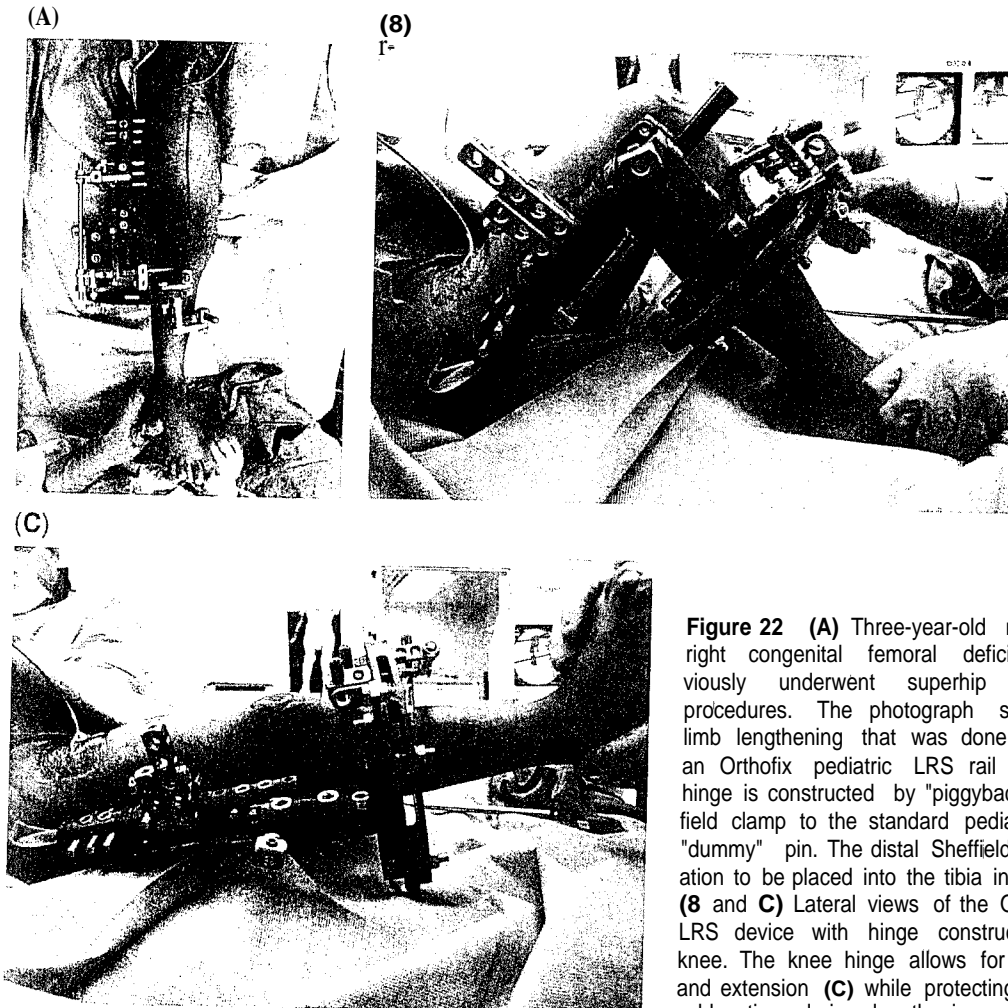

Figure 22 (A) Three-year-old male patient with right congenital femoral deficiency who previously underwent superhip and superknee procedures. The photograph shows the initial limb lengthening that was done with the use of an Orthofix pediatric LRS rail system. A knee hinge is constructed by "piggybacking" the Sheffield clamp to the standard pediatric clamp via a "dummy" pin. The distal Sheffield arch allows fixation to be placed into the tibia in multiple planes. (B and C) Lateral views of the Orthofix pediatric LRS device with hinge construct bridging the knee. The knee hinge allows for full flexion (B) and extension (C) while protecting the knee from subluxation during lengthening.

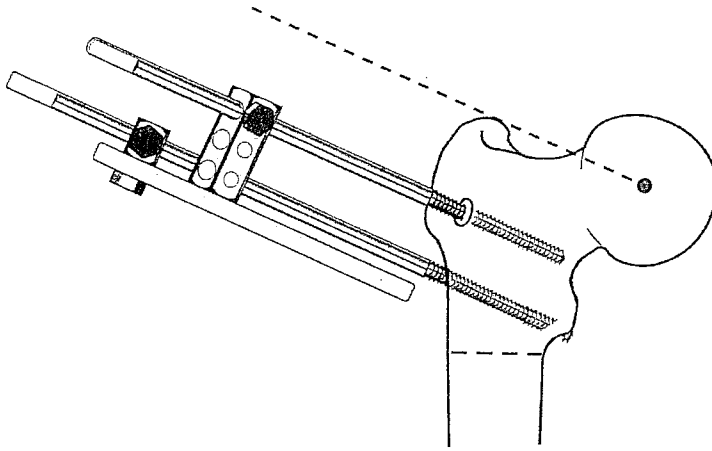

Figure 23 First pin is inserted in the frontal plane from lateral to medial. The pin is directed parallel to the proximal orientation line from the tip of the greater trochanter to the center of the femoral head. *Source:* Modified from Ref. 7.

the first pin. The proximal arch is perpendicular to the floor with the limb crossed over and externally rotated. This allows correction of the varus, flexion, and external rotation deformities. Two Ilizarov rings are applied to the distal femoral reference wire, parallel to the knee joint. For young children, arthrograms are obtained for the purpose of outlining the cartilaginous femoral condyles. This also allows visualization of the posterior femoral condyles in the sagittal plane for hinge placement. Conical washers or hinges are used between the two distal rings because of the valgus of the distal femur. The rings are at the valgus deformity angle to each other. A lateral half-pin is inserted into the midsegment of the femur and attached to the middle ring. This pin is at 7° to the shaft of the bone. The proximal subtrochanteric osteotomy can then be performed. The osteotomy is performed percutaneously by creating multiple drill holes and completing the osteotomy with an osteotome. The osteotomy is internally rotated, laterally translated, and then angulated into valgus and extension to correct all components of the deformity. The order of correction is important to achieve the necessary displacement without loss of bone-to-bone contact and stability (Fig. 24). Two additional half-pins are inserted and fixed onto the distal ring, one from posteromedial and one from posterolateral between the quadriceps and the hamstring muscles. An additional pin is placed in the middle segment. In small children, all half-pins are inserted by using the cannulated drill technique. This technique permits very accurate placement of large diameter pins in narrow bones to avoid eccentric placement. Eccentric placement of drill holes and half-pins in the femoral diaphysis leads to fracture. Next, the distal femoral osteotomy is performed percutaneously, with multiple drill holes and an osteotome. The previously placed reference wire is removed to avoid tethering of the quadriceps and fascia lata.

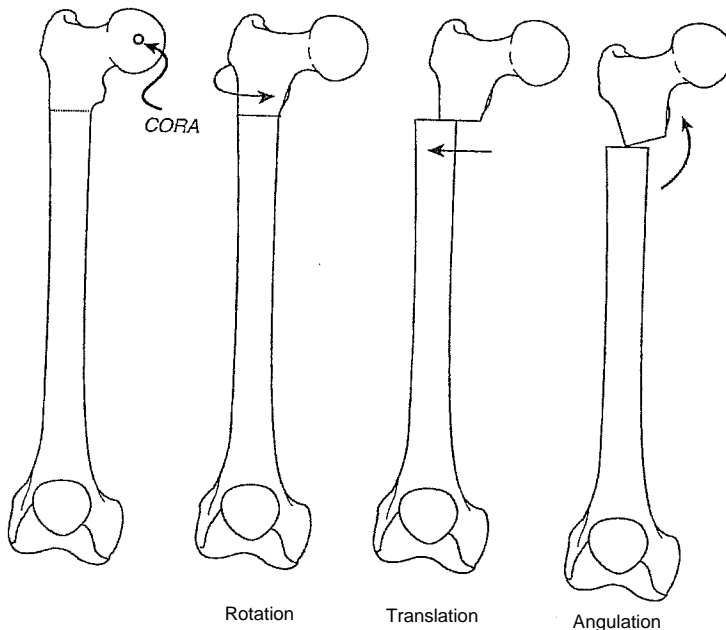

Figure 24 Sequence of deformity correction is essential to obtain the correction and maintain stability, and bone contact. *Source:* Modified from Ref. 7.

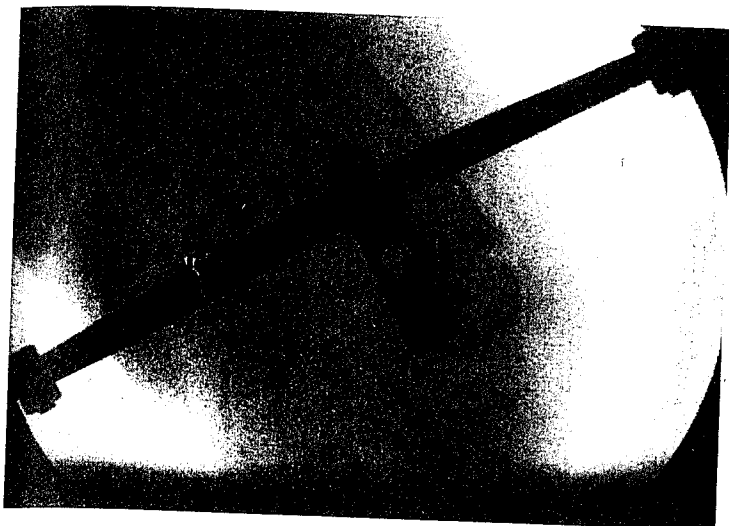

Figure 25 Intraoperative fluoroscopic view of Ilizarov hinge placement at the point of intersection of the posterior femoral diaphyseal line and the distal femoral physis.

Knee Hinges

The last step is to extend the fixation to the tibia by using hinges placed at the center of rotation of the knee. The center of rotation of the knee is located at the intersection of the posterior femoral cortical line and the distal femoral physeal line (15) in the plane in which the two posterior femoral condyles are seen to overlap on the lateral view (Fig. 25). For younger children, an arthrogram of the knee allows visualization of the posterior femoral condyles. The distal femoral ring, which is parallel to the knee, must appear to be perpendicular to the X-ray beam. The medial and lateral skin is marked at the location of the planned hinge placement. Two threaded rods with female hinges attached are dropped from the distal femoral ring to the marked level of the knee hinge. A single half-ring is attached to two threaded rods and attached to the hinges. This half-ring is oriented perpendicular to the tibia with the knee in full extension. The first half-pin is inserted from anterior to posterior into the tibia. After this pin is secured to the proximal tibial half-ring, the knee is flexed and extended through a range of motion. If this range feels frictionless (perform a drop test; drop the tibia to see whether it flexes without any catch), second and third tibial half-pins are added. Finally, a removable knee extension bar is inserted between the distal femoral ring and the tibial half-ring.

Distal Femoral Lengthening: Orthofix Fixator Technique

Start by identifying the center of rotation of the knee joint (see description above). A 1.8-mm wire is drilled into the lateral edge of the physis at the intersection of the posterior cortex of the femur, with the physis in line with the plane of overlap of the posterior femoral condyles (Fig. 26). The Orthofix (McKinney, Texas, U.S.A.) LRS rail system (pediatric or adult) is lined up with the hinge axis through its most distal clamp hole. A commercially available sandwich clamp is used. (If this is unavailable, one can fashion a sandwich clamp by using two pin clamp lids held to the pin clamp body by a 30-mm Ilizarov bolt and the convex conical washer for centering in the hole.) The sandwich clamp provides a second layer of pin holes more anteriorly (Fig. 27). The fixator bar is aligned with the shaft of the femur and the most proximal half-pin inserted into the proximal femur. The distal-most pin is then drilled one hole proximal and anterior to the center of rotation reference wire. For ease of application, an LRS without sandwich clamps is used to place the remaining pins (three proximal and three distal). If distal femoral valgus is present and is to be corrected acutely, a swivel clamp is used for distal pin placement. When using a pediatric LRS, the three-hole pin clamp contains only two half-pin sites because one hole is occupied for the knee center of rotation wire. A third pin is added by using an Ilizarov cube connected to the two pins (Fig. 28). Before reapplying the sandwich clamps, the osteotomy is performed and the distal valgus is corrected acutely. After the correction, the fixator can be exchanged for another fixator with straight clamps and sandwich attachments. All the pins should be in the upper deck of the double-decker sandwich clamp distally. The only pin in the lower deck is the knee axis pin. The knee axis pin is a dummy pin that does not enter the patient's limb. It is a segment of pin that protrudes laterally from the

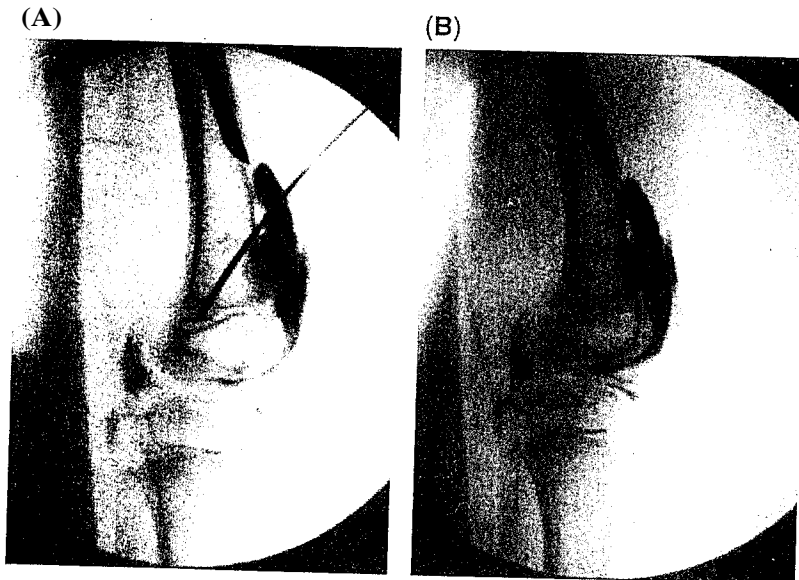

Figure 26 (A and B) Intraoperative fluoroscopic images show arthrography of the knee. The lateral view is obtained, and the posterior aspects of the femoral condyles are superimposed to create the perfect lateral view. The hinge reference wire is inserted at the intersection of the posterior femoral cortical line and the distal femoral physis. This marks the center of rotation of the knee joint.

clamp. A Sheffield clamp from Orthofix is applied to this pin to act as a hinge. It is locked in place by placing a cube lateral to it with a setscrew to prevent it from moving laterally. Conical washers are used between the Sheffield clamp and the LRS to reduce friction (Fig. 29). The Sheffield clamp is left partially loose to permit motion. A one-third Sheffield arch is attached to the clamp, arching toward the tibia. An anteroposterior pin is inserted, and the drop test is performed (see above). If friction occurs during the drop, the Sheffield clamp should be loosened. If friction persists, adjust the connection of the tibial pin to the Sheffield arch. If friction further persists after the adjustment, the axis pin might need to be bent slightly to alter the axis of rotation. Once the drop test is negative, two more oblique pins are inserted into the tibia and connected to the Sheffield arch by using cubes (Fig. 30). A removable knee extension bar is fashioned from Ilizarov parts to be used especially at nighttime. The easiest way to accomplish this is to apply a cube to the protruding ends of the distal pins and build off this cube with a post (Fig. 31). If an unstable hip is present, a hinge axis pin for the hip can also be placed and attached to the proximal clamp. The same Sheffield clamp and arch arrangement are used. Three pins are placed in the pelvis, one through the anterior-inferior and one through the anterior-superior spines extending posteriorly. One is inserted laterally. These are fixed to the Sheffield clamp to prevent proximal subluxation of the hip during lengthening (Fig. 32). As one can see, the principles applied when using monolateral fixation are the same as those for circular fixation (i.e., hinge fixation across joints when a joint is at risk).

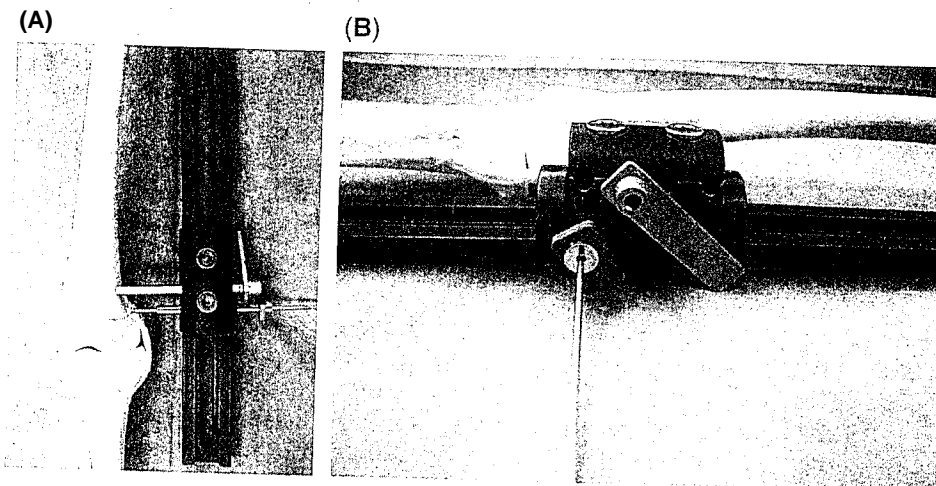

Figure 27 (A and B) Bone model shows LRS sandwich clamp placed distally, with the most distal hole containing the hinge axis wire. The first distal half-pin is placed on the anterior row one hole proximal to the hinge axis pin.

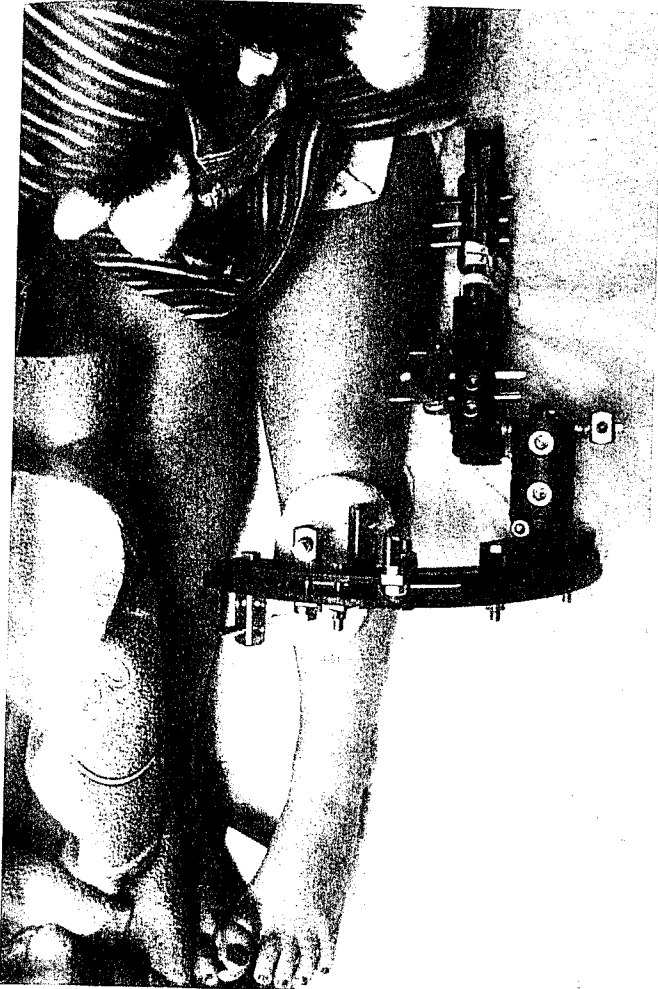

Figure 28 Example of pediatric Orthofix rail with a three-hole cube placed on the distal half-pins to allow a third half-pin to be inserted into the distal fragment.

REHABILITATION AND FOLLOW-UP DURING LENGTHENING

Femoral lengthening requires close follow-up and intensive rehabilitation to identify problems and maintain a functional extremity. Follow-up is usually conducted every two weeks for radiographic and clinical assessments. Clinically, the patient is assessed for hip and knee range of motion, knee subluxation, nerve function, and pin site problems. Radiographically, the distraction gap length, regenerate bone quality, limb alignment, and joint location are assessed.

Physical therapy is begun within one or two days after surgery and should continue daily throughout the distraction and consolidation phases. Physical therapy is briefly discontinued

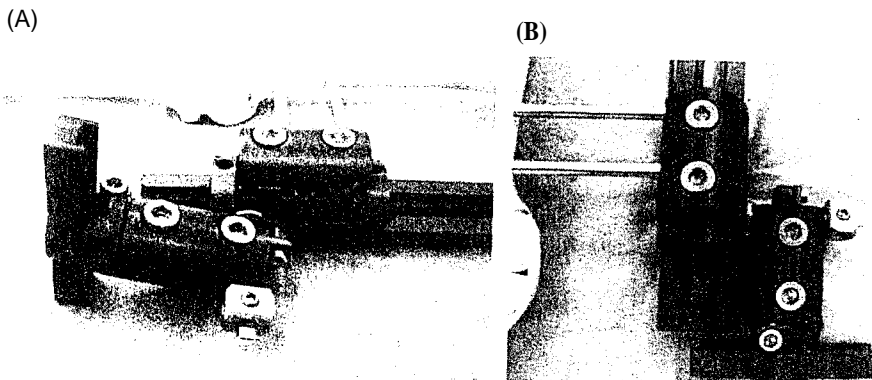

Figure 29 (A and B) Bone model with a dummy pin inserted into the distal posterior hole of the LRS sandwich clamp that replaces the hinge axis wire. A Sheffield clamp is attached to the hinge dummy pin to create the knee hinge.

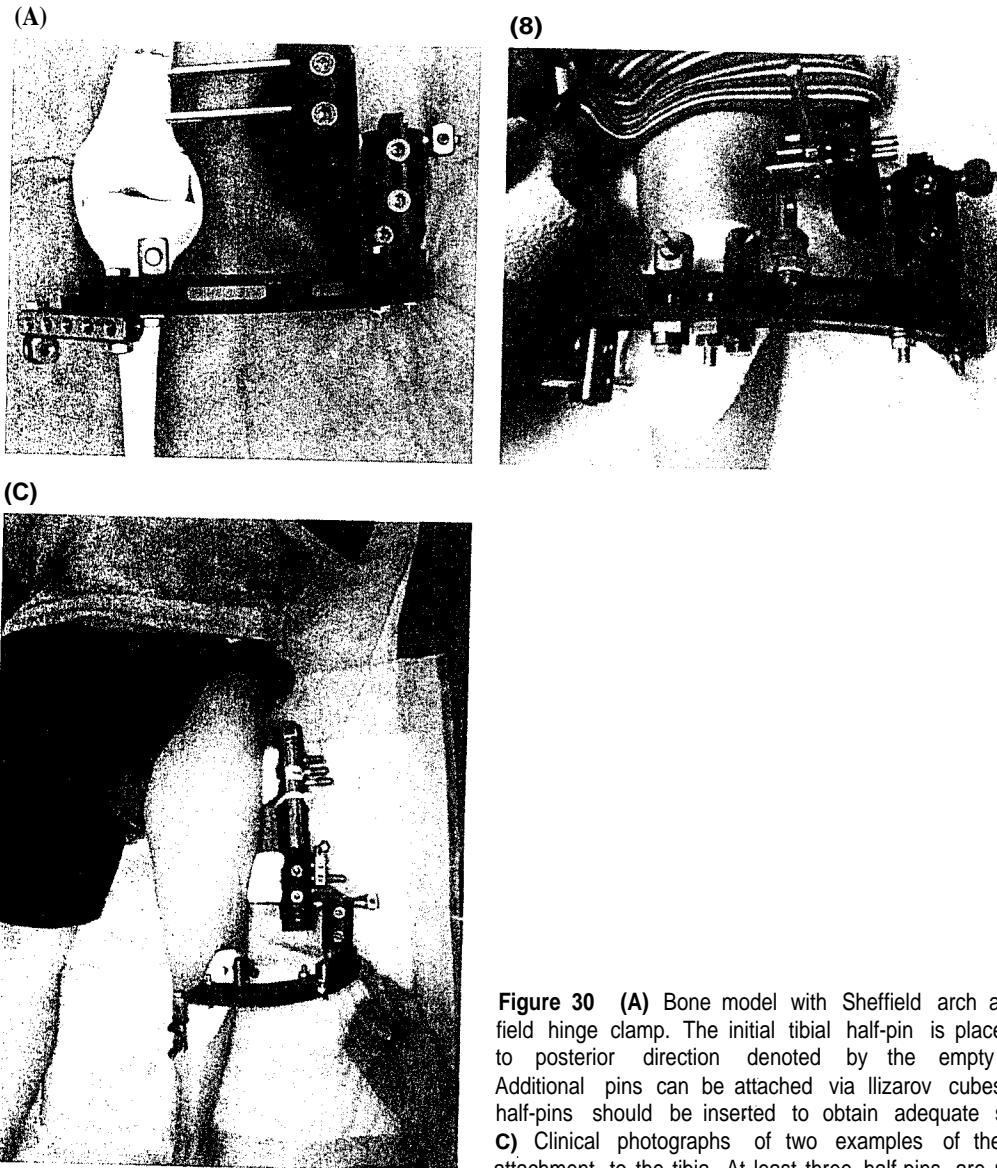

Figure 30 (A) Bone model with Sheffield arch attached to Sheffield hinge clamp. The initial tibial half-pin is placed in an anterior to posterior direction denoted by the empty Ilizarov cube. Additional pins can be attached via Ilizarov cubes. At least three half-pins should be inserted to obtain adequate stability. (B and C) Clinical photographs of two examples of the Sheffield arch attachment to the tibia. At least three half-pins are used for fixation.

After removal of the external fixator to avoid a fracture through the regenerate bone or a pin hole. Once the bone is strong enough, physical therapy is continued. During the distraction phase, one or two formal sessions with a therapist are required each day (45-60 minutes each session). In addition, at least two home sessions per day (30 minutes each) are recommended. The more physical therapy is performed, the better the functional result will be. The philosophy of therapy for

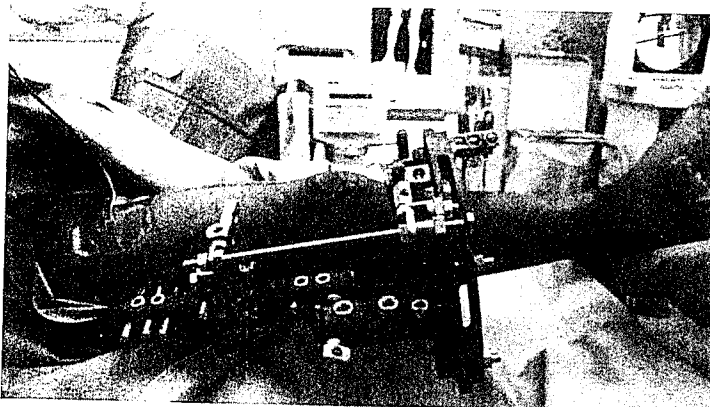

Figure 31 Clinical photograph shows a completed Orthofix external fixator for femoral lengthening in a patient with congenital femoral deficiency. The knee extension bar is constructed by building Ilizarov cubes from the half-pins to the Sheffield arch. Sockets are used to connect the extension bar to the frame, which allows for easy removal of the bar during physical therapy.



Figure 32 Radiograph shows a monolateral Orthofix external fixator bridging across the hip joint to prevent subluxation. The hip hinge is created by using a dummy half-pin at the center of hip rotation, which is connected to a Sheffield clamp and arch.

lengthening is very different from that for other orthopedic surgical procedures. With most orthopedic procedures, the patients are at their worst after surgery and recover gradually. Patients undergoing lengthening are at their best one week after surgery. Thereafter, because of the distraction, the muscles become tighter and the range of motion of the joints is more limited. It is not until the consolidation phase that the usual pattern of rehabilitation and recovery occurs. One can think of the lengthening surgery ending at the end of the distraction phase: a surgical procedure that can be measured in months, rather than hours. In the absence of a therapy program, we will not even consider performing femoral lengthening.

The majority of the therapy time should be spent obtaining knee flexion and maintaining knee extension. Passive exercises are most important during the distraction phase, and passive plus active exercises are most important during the consolidation phase. Hip abduction and extension are the two important hip exercises. Strengthening exercises should be focused on the hip abductors and the quadriceps. Electric stimulation is applied to the quadriceps muscle. Upper extremity strengthening is helpful for use of walking aids and transfers. Weight bearing is encouraged and allowed as tolerated.

Knee flexion should be maintained at more than 45° . If knee flexion is 40° or less, the lengthening should be discontinued or at least slowed and knee rehabilitation should be increased. If, after a few days, the knee flexion improves, lengthening can resume. Our motto is "never sacrifice function for length." More length can be obtained with subsequent lengthenings, but a new knee joint cannot be created. Therefore, preserving the knee joint and its motion is most important. Flexion contracture might develop during lengthening. To prevent this, a knee extension bar can be used at night and part-time during the day. FFD of the knee places it at risk for posterior subluxation. Subluxation of the knee can be suspected clinically based on a change in shape of the front of the tibia relative to the patella. Posterior subluxation of the tibia presents with a very prominent patella and a depression of the tibia relative to the patella (ski hill sign). Extension of the external fixation across the knee with hinges prevents posterior subluxation.

Hip motion can become more limited with lengthening. Adduction and flexion contractures are the most significant because they lead to hip subluxation and dislocation. Release of

the adductors, rectus, and TFL during lengthening might need to be considered to allow further lengthening. Usually the TFL and the rectus femoris tendon are addressed during the preparatory surgery.

Nerve injury from surgery or distraction is unusual with femoral lengthening. To avoid peroneal nerve injury from the pins, the posterolateral pin should not enter posterior to the biceps tendon. During distraction, if the patient complains of pain in the dorsum of the foot or requests frequent massaging of the foot, referred pain from stretch entrapment of the peroneal nerve is most likely the cause. More advanced symptoms include hyper- or hypoesthesia in the distribution of the peroneal nerve and weakness of the extensor hallucis longus muscle. Quantitative sensory testing, if available, is the most sensitive test to assess for nerve involvement. If the nerve problem is identified early, it can be treated by slowing the rate of distraction. If, despite slowing the distraction, symptoms continue or motor signs develop, the peroneal nerve should be decompressed at the neck of the fibula. This release should include transverse fasciotomy of the lateral and anterior compartments and release of the intermuscular septum between these compartments (7).

Hypotrophic regenerate formation requires slowing the distraction rate. Overabundant bone formation can lead to premature consolidation and requires increasing the distraction rate for a few days. A mismatch between the increase in the distraction gap from one visit to the next and the number of millimeters of distraction performed during the same time period is a sign of an impending premature consolidation. Radiographs are used to assess joint location. A break in Shenton's line or increased medial-lateral head-teardrop distance indicates subluxation of the hip. In the knee, posterior or anterior subluxation can be monitored on the lateral radiographic view with full knee extension (16). Limb length equalization should be based on full-length standing radiographs. Limb alignment is assessed for the femur and tibia separately and in combination. Separately the joint orientation of the knee should be measured by using the malalignment test (7). Axial deviation from lengthening (procurvatum and valgus for distal femoral lengthening and procurvatum and varus for proximal lengthening) is identified and corrected at the end of the distraction phase, when the regenerate bone is still malleable. When malalignment of the femur and tibia is present, the femoral malalignment is corrected to a normal distal femoral joint orientation. The femur is not over- or undercorrected to compensate for the tibial deformity. The tibia should be corrected separately, either during the same treatment or at a later treatment.

Complete failure of bone formation is very unusual. Partial defects are not uncommon. The most common location of regenerate defects is lateral. Dynamization of the fixator should be performed, and bone growth stimulators can be used. Resection of the fibrous tissue in these defects and cancellous bone grafting might become necessary to reduce the external fixation time and prevent fracture after frame removal.

Once the regenerate bone is deemed healed, the frame can be removed from the femur and tibia. Previously, we applied a one-legged spica cast to prevent fracture. Despite application of the cast, we experienced a 34% fracture rate of the femur after removal, compared with a 9% fracture rate for all other bones and for noncongenital femoral lengthening. Because of this high fracture rate, prophylactic Rush rod placement in the femur is now performed at the time of external fixation removal. This new protocol has virtually eliminated the complication of refracture after lengthening. Because a rod is being inserted into the femur at the time of removal of the external fixator, intramedullary infection is a concern. Despite this concern, we have observed only two cases in which local deep pin bone infection occurred. The infections were easily treated by curettage of the lateral cortex of the bone combined with removal of the Rush rod and administration of antibiotics. Prophylactic rodding permits continuation of knee mobility after removal. Formal physical therapy is delayed for a month, but the patient is permitted gentle knee range of motion. This is to protect from osteoporotic stress fractures through the tibial pin holes. The prophylactic rod placement also permits weight bearing with a removable spica cast immediately after frame removal.

DIFFERENCES IN TREATMENT OF TYPES 1a AND 1b CONGENITAL FEMORAL DEFICIENCY

In general, Type 1a CFD (normal ossification) has less hip, proximal femoral, and knee deformity, deficiency, and discrepancy than does Type 1b (delayed ossification). Most Type 1a cases do

not require the complex superhip reconstruction. Approximately one-half of the Type Ia cases do require pelvic osteotomy before lengthening. All CFD Type Ia cases require extension of the fixator across the knee to protect the knee joint. The distinction between Types Ia and Ib should be made while the patient is in infancy because the natural history of Type Ib is to ossify. Therefore, adult Type Ib cases generally appear to be severe Type Ia cases. The strategy of treatment for Type Ib is to correct all the associated deformities, which will allow the proximal femur and hip to be more normally oriented and accept more axial loading. The response to the anatomic change is ossification of the proximal femur and conversion from Type Ib to Type Ia. We do not perform lengthening in Type Ib cases until they convert to Type Ia. This conversion usually occurs within two years of the superhip procedure. Our preference is to perform the first lengthening when the patient is between the ages of two and four years. Patients with Type Ia CFD typically undergo their first lengthening at the age of two years, whereas patients with Type Ib CFD typically undergo lengthening closer to the age of four years.

TREATMENT OF TYPES 2 AND 3 CONGENITAL FEMORAL DEFICIENCY

Detailed discussion of the treatment of Types 2 and 3 CFD are complex and beyond the scope of this textbook. For the purposes of this text, we provide only a summary of our strategy for Types 2 and 3.

Type 2 Congenital Femoral Deficiency

With Type 2 CFD, the deciding factor is the presence or absence of a mobile femoral head in the acetabulum. Despite magnetic resonance imaging, arthrography, and other studies, often the only definitive way to determine the presence or absence of a mobile femoral head is to open the hip joint capsule and examine the femoral head for mobility. If the femoral head does not move in the acetabulum, it should not be joined to the femoral shaft. If it is joined to the femoral shaft, effectively, arthrodesis of the hip is created. If the femoral head is mobile, it can be connected to the remainder of the femur by a complicated reconstruction of the femoral neck, which we call "superhip 2." This converts Type 2a to Type Ia, and further treatment is as for Type Ia. If no femoral head is present or if it is stiff in the acetabulum, only the superhip soft tissue release is performed to release the flexion contracture of the hip and excise the fascia lata. Serial lengthenings with fixation to the pelvis are performed until skeletal maturity, at which time the last lengthening is combined with a pelvic support osteotomy. The only difference between pelvic support osteotomy in cases of CFD and that for other conditions (17) is that the fixation is extended to the pelvis.

Type 3 Congenital Femoral Deficiency

Type 3a CFD can be treated like Type 2b, with hip release, serial lengthenings, and pelvic support osteotomy, or can be treated by prosthetic fitting options, including prosthetic reconstruction surgery. Prosthetic reconstruction surgery refers to Syme amputation and rotationplasty. For Type 3b CFD, which includes a stiff knee joint ($\ll 45^\circ$ of motion), we are more likely to recommend prosthetic reconstruction surgery. In Type 3a cases, when the knee joint has a functional range of motion, converting Type 3a to Type 2b can be considered. The extent of treatment required for reconstruction in such cases entails four or more lengthenings and should not be considered lightly. Rotationplasty provides more predictable functional results than does lengthening for such severe cases. When rotationplasty is chosen, our preference is to use a modification of the rotationplasty described by Brown (18). This includes fusion of the distal femoral remnant to the pelvis. Paley's modification is to perform the fusion to the inferior iliac surface of a Chiari osteotomy instead of to the lateral ileum as described by Brown. This medializes the limb and provides a broader surface for fusion. The femoral segment is fixed to the pelvis by using screws crossing the physis to produce a distal femoral epiphysiodesis. Distal femoral epiphysiodesis is required to prevent distal migration of the rotated knee joint (functionally now the hip joint). When Syme amputation is chosen, the superhip approach to eliminate contractures around the hip, combined with knee flexion contracture release, improves the posture of the short thigh and knee joint to enable better prosthetic fitting.

AGE STRATEGIES (TABLE 1)

The majority of Type 1 CFD cases require at least two lengthenings (Table 1). Because the expected discrepancy at skeletal maturity increases, the number of lengthenings required to equalize LLD increases. Our preferred strategy is to perform the first lengthening when the patient is between the age of two and four years. We have found that children between the age of 4.5 and 6 years are often not at the optimal age psychologically to deal with limb lengthening. Their cognitive level is insufficient to understand why their parents allowed someone to do this to them, despite that they are beginning to be more independent and might seem to be mature enough to handle the process. The younger children do much better because their cognitive level accepts everything their parents decide without question. Children between 4.5 and 6 years of age seem to understand too little and too much at the same time. They do not connect their recognition that they have a short limb with the solution of limb lengthening. Beyond the age of six years, children enter the age of reason and begin to understand that they are different from other children and that they have a problem for which there is a solution. They learn to accept the solution by reason rather than by faith. Their cooperation is voluntary rather than coerced. The amount of lengthening that can be attained in the femur at anyone stage usually is between 5 and 8 cm. This lengthening amount seems to be independent of the initial length of the femur and age of the child. Generally, 5 to 8 cm can be safely attained in toddler (age two to four years) femora as well as in older children and adult femora, despite that the percentage of lengthening is greater in the toddler. Combined femoral and tibial lengthenings allow greater total lengthening amounts. Tibial lengthening of 5 cm or lower can be combined with a 5-cm femoral lengthening. Femoral lengthening in children younger than six years can be associated with sustained growth stimulation (19). By beginning lengthening at a young age, we are able to reduce one or more levels of prosthetic/ orthotic need. This means going from a knee-ankle-foot orthosis to an ankle-foot orthosis and shoe lift, or from an ankle-foot orthosis and shoe lift to a shoe lift only, or from a shoe lift to no lift. The complication rate in this young age group is no higher than in older children, in our experience.

Adults (age 18-60 years) with CFD whose parents refused prosthetic reconstruction surgery for them when they were children have undergone limb lengthening. We were able to successfully equalize their limb lengths with one or two lengthenings, depending on the discrepancy (the most severe case underwent 25 cm of equalization two LON treatments). Therefore, adult CFD residua are not contraindications to treatment.

Table 1 Treatment Strategies and Timing of Reconstructive Stages in Management of Congenital Femoral Deficiency

Predicted LLD at maturity	Number of procedures	Timing and amount of lengthening
≤6 cm	1 Lengthening	Age > 6 yr
7-12 cm	2 Lengthenings	Age 2-4 yr, ≤6 cm; age 8-14 yr, < 8 cm
	1 Lengthening	Age 2-4 yr, ≤6 cm or age 6-10 yr, < 8 cm + epiphysiodesis of < 5 cm
12-16 cm	2 Lengthenings	Age 2-4 yr, < 7 cm or age 6-8 yr, 6-8 cm + age 10-14 yr, 8 cm
16-20 cm	2 Lengthenings	Age 2-4 yr, ≤6 cm or age 6-8 yr, < 8 cm + age 10-14 yr, 8 cm + tibia < 5 cm during one femoral lengthening
	3 Lengthenings	Age 2-4 yr, ≤6 cm + age 8-10 yr, 6-8 cm + age 10-14 yr, 8 cm
	2 Lengthenings	Age 2-4 yr, ≤6 cm + age 10-14 yr, 8 cm + epiphysiodesis of < 5 cm
21-25 cm	3 Lengthenings	Age 2-4 yr, < 5 cm + age 8-10 yr, 6-8 cm + age 12-14 yr, 10-12 cm
	3 Lengthenings	Age 6-8 yr, < 8 cm + age 10-12 yr, 8 cm + age 12-16 yr, 8-12 cm + tibia < 5 cm during one femoral lengthening
	2 Lengthenings	Age 6-8 yr, < 8 cm + age 10-12 yr, 8 cm + epiphysiodesis of 5 cm + tibia < 5 cm during one femoral lengthening + epiphysiodesis of < 5 cm
>25 cm	3 Lengthenings	+ epiphysiodesis of 5 cm
	4 Lengthenings	

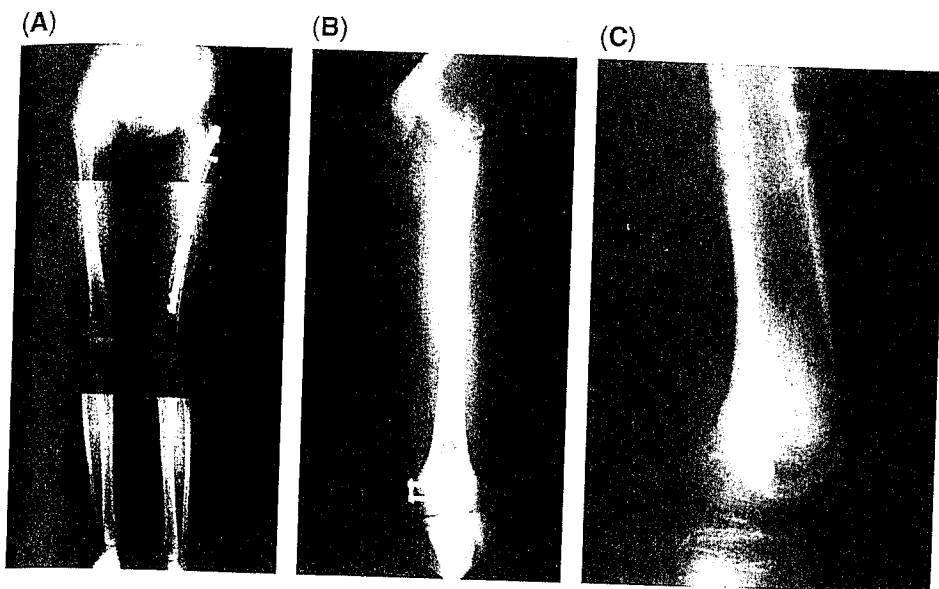

Figure 33 (A-C) Radiographs of a 10-year-old female patient undergoing femora/lengthening with an intramedullary lengthening nail and concurrent genu valgus secondary to congenital femoral deficiency. At the time of intramedullary skeletal kinetic distractor nail removal, a distal femoral hemiepiphyodesis is performed with the Orthofix eight-Plate device for gradual correction of the valgus deformity.

ROLE OF EPIPHYSIODESIS AND HEMIEPIPHYSIODESIS

Epiphysiodesis is used as an adjuvant method to equalize LLD. It should be calculated into the total strategy of equalization surgeries. Epiphysiodesis should be used for 5 cm or less of LLD equalization. Judicious use in some cases might avoid the need for one lengthening (e.g., predicted LLD = 11 cm; plan 6 cm of lengthening before age four years and 5 cm of epiphysiodesis near puberty). Calculation of the timing of epiphysiodesis can be achieved by using the Anderson and Green method (20) or Moseley (21) method or more simply and accurately by using the multiplier method (22,23).

Hemiepiphyodesis is very useful to correct the valgus deformity of the knee from distal-femoral or proximal-tibial origins. We currently prefer to use the Orthofix eight-Plate device, developed by Dr. Peter Stevens of the University of Utah, rather than Blount staples. Correction of the valgus deformity of the femur permits internal lengthening of the femur with an intramedullary lengthening device (ISKD) after the knee deformity is corrected (Fig. 33).

REFERENCES

- Sanpera I Jr., Sparks LT. Proximal femoral focal deficiency: does a radiologic classification exist? *J Pediatr Orthop* 1994; 14(1):34-38.
- Paley D. Lengthening reconstruction surgery for congenital femoral deficiency. In: Herring JA, Birch JG, eds. *The Child with a Limb Deficiency*. Rosemont: American Academy of Orthopaedic Surgeons, 1998:113-132.
- Millis ME, Hall JE. Transiliac lengthening of the lower extremity: a modified innominate osteotomy for the treatment of postural imbalance. *J Bone Joint Surg Am* 1979; 61(8):1182-1194.
- Langenskiöld A, Ritsila V. Congenital dislocation of the patella and its operative treatment. *J Pediatr Orthop* 1992; 12(3):315-323.
- Amirault JD, Cameron JC, MacIntosh DL, Marks P. Chronic anterior cruciate ligament deficiency: long-term results of MacIntosh's lateral substitution reconstruction. *J Bone Joint Surg Br* 1988; 70(4):622-624.
- Grammont PM, Lattne D, Lammaire IF. Treatment of subluxation and dislocation of the patella in the child: Elmslie technique with movable soft tissue pedicle (8 year review) [in German]. *Orthopäde* 1985; 14(4):229-238.
- Paley D: *Principles of Deformity Correction*. Berlin: Springer-Verlag, 2002.
- Krackow KA, Thomas SC, Jones LC. A new stitch for ligament-tendon fixation: brief note. *J Bone Joint Surg Am* 1986; 68(5):764-766.
- Gordon JE, Goldfarb CA, Lühmann SJ, Lyons D, Schoenecker PL. Femoral lengthening over a humeral intramedullary nail in preadolescent children. *J Bone Joint Surg Am* 2002; 84(6):930-937.

10. Paley D, Herzenberg IE, Paremain G, Bhave A. Femoral lengthening over an intramedullary nail: a matched-case comparison with Ilizarov femoral lengthening. *J Bone Joint Surg Am* 1997; 79(10):1464-1480.
11. Thonse R, Herzenberg JE, Standard SC, Paley D. Limb lengthening with a fully implantable, telescopic, intramedullary nail. *Oper Tech Orthop* 2005; 15(4):355-362.
12. Woolf SK, Gross RH. Posterior acetabular wall deficiency in down syndrome. *J Pediatr Orthop* 2003; 23(6):708-713.
13. Koman LA, Brashear A, Rosenfeld S, et al. Botulinum toxin type A neuromuscular blockade in the treatment of equinus foot deformity in cerebral palsy: a multicenter, open-label clinical trial. *Pediatrics* 2001; 108(5):1062-1071.
14. Bowen JR, Levy EJ, Donohue M. Comparison of knee motion and callus formation in femoral lengthening with the Wagner or monolateral-ring device. *J Pediatr Orthop* 1993; 13(4):467-472.
15. Hollister AM, Jaitana S, Singh AK, Sullivan WW, Lupichuk AG. The axes of rotation of the knee. *Clin Orthop Relat Res* 1993; 290:259-268.
16. Paley D. Problems, obstacles, and complications of limb lengthening by the Ilizarov technique. *Clin Orthop Relat Res* 1990; 250:81-104.
17. Rozbruch SR, Paley D, Bhave A, Herzenberg IE. Ilizarov hip reconstruction for the late sequelae of infantile hip infection. *J Bone Joint Surg Am* 2005; 87(5):1007-1018.
18. Brown KL. Resection, rotationplasty, and femoropelvic arthrodesis in severe congenital femoral deficiency: a report of the surgical technique and three cases. *J Bone Joint Surg Am* 2001; 83(1):78-85.
19. Sabharwal S, Paley D, Bhave A, Herzenberg IE. Growth patterns after lengthening of congenitally short lower limbs in young children. *J Pediatr Orthop* 2000; 20(2):137-145.
20. Anderson M, Messner MB, Green WT. Distribution of lengths of the normal femur and tibia in children from one to eighteen years of age. *J Bone Joint Surg Am* 1964; 46:1197-1202.
21. Moseley CF. A straight-line graph for leg-length discrepancies. *J Bone Joint Surg Am* 1977; 59(2):174-179.
22. Aguilar JA, Paley D, Paley J, et al. Clinical validation of the multiplier method for predicting limb length at maturity, part I. *J Pediatr Orthop* 2005; 25(2):186-191.
23. Aguilar JA, Paley D, Paley J, et al. Clinical validation of the multiplier method for predicting limb length discrepancy and outcome of epiphysiodesis, part II. *J Pediatr Orthop* 2005; 25(2):192-196.